



**KERN & Sohn GmbH**

Ziegelei 1

D-72336 Balingen

E-Mail: [info@kern-sohn.com](mailto:info@kern-sohn.com)

Tel: +49-[0]7433- 9933-0

Fax: +49-[0]7433-9933-149

Internet: [www.kern-sohn.com](http://www.kern-sohn.com)

# Operating Instructions

## Electronic crane scale

### KERN HTS

Version 2.3

10/2009

GB



HTS-BA-e-0923

ME-Nr. 71209203-D

- D** Weitere Sprachversionen finden Sie online unter **www.kern-sohn.com/manuals**
- CZ** Další jazykové verze najdete na webu pod adresou **www.kern-sohn.com/manuals**
- DK** Yderligere sprogversioner finder de online på **www.kern-sohn.com/manuals**
- E** Más versiones de idiomas se encuentran online bajo **www.kern-sohn.com/manuals**
- EST** Rohkem keeli internetis aadressil **www.kern-sohn.com/manuals**
- F** Vous trouverez d'autres versions de langue online sous **www.kern-sohn.com/manuals**
- GB** Further language versions you will find online under **www.kern-sohn.com/manuals**
- H** A használati utasítás egyéb nyelveken a **www.kern-sohn.com/manuals** címről tölthető le
- I** Trovate altre versioni di lingue online in **www.kern-sohn.com/manuals**
- N** Ytterligere språkversjoner finner du online under **www.kern-sohn.com/manuals**
- NL** Bijkomende taalversies vindt u online op **www.kern-sohn.com/manuals**
- P** Encontram-se online mais versões de línguas em **www.kern-sohn.com/manuals**
- PL** Inne wersje językowe znajdują Państwo na stronie **www.kern-sohn.com/manuals**
- RUS** Другие языковые версии Вы найдете по адресу в Интернете **www.kern-sohn.com/manuals**
- S** Ytterligere språkversioner finns online under **www.kern-sohn.com/manuals**
- SF** Muita kieliversioita löydät osoitteesta **www.kern-sohn.com/manuals**
- SLO** Ostale jezikovne različice boste našli online na **www.kern-sohn.com/manuals**
- TR** Diğer lisan versiyonlarını internetten **www.kern-sohn.com/manuals** adresinden temin edebilirsiniz



# KERN HTS

Version 2.3 10/2009

## Operating Instructions Electronic crane scale

### Contents

<b>1. Technical specifications</b>	<b>5</b>
1.1 Small construction	5
1.2 Large construction	7
1.3 Dimensions	9
<b>2. Declaration of conformity</b>	<b>12</b>
<b>3. General Safety Instructions</b>	<b>18</b>
<b>4. Crane scale at a glance</b>	<b>20</b>
4.1 Overview	20
4.2 Display	22
4.3 Keyboard	23
4.4 Remote control	24
<b>5. Commissioning</b>	<b>25</b>
5.1 Unpacking (large construction)	25
5.2 Unpacking (large and small construction)	25
5.3 Checking the original dimensions	25
5.4 Recharge the battery	26
5.5 Suspend scale	28
<b>6. Operation</b>	<b>29</b>
6.1 Safety instructions	29
6.2 Load the crane scale	29
6.3 Turn on/off	32
6.4 Resetting the scale	32
6.5 Taring	33
6.6 Working with the tare weights saved	34
6.7 Weighing	36
6.8 Accumulation	36
6.9 Displaying peak weight	38
6.10 Weighing with a tolerance range	39
6.11 Stop weight value (freeze)	39
6.12 Battery operation	40
6.13 Operation with remote control	41

<b>7.</b>	<b>User menu .....</b>	<b>42</b>
7.1	Overview .....	42
7.2	Accessing the user menu .....	42
7.3	Operation in menu .....	43
7.4	Description of the user menu .....	46
<b>8.</b>	<b>Service menu.....</b>	<b>49</b>
8.1	Overview .....	49
8.2	Access service menu .....	50
8.3	Description of service menu .....	51
8.4	Verification .....	57
<b>9.</b>	<b>Error messages.....</b>	<b>59</b>
<b>10.</b>	<b>Maintenance &amp; Cleaning.....</b>	<b>60</b>
10.1	Regular maintenance .....	60
10.2	Checklist for regular safety inspections .....	62
10.3	Cleaning .....	65
10.4	Changing the batteries of the remote control .....	65
<b>11.</b>	<b>Enclosure .....</b>	<b>66</b>
11.1	Checklist extended safety inspection .....	66
11.2	Proof of replacement and repair of safety relevant parts .....	67

# 1. Technical specifications

## 1.1 Small construction

<b>KERN</b>	<b>HTS150K 50IP</b>	<b>HTS300K 100IP</b>	<b>HTS600K 200IP</b>	<b>HTS1.5T 0.5IP</b>
Readability (d)	50 g	100 g	200 g	500 g
Weighing range (Max)	150 kg	300 kg	600 kg	1500 kg
Taring range (subtractive)	150 kg	300 kg	600 kg	1500 kg
Reproductability	50 g	100 g	200 g	500g
Linearity	± 100 g	± 200 g	± 400 g	± 1000g
Verifiable	no	no	no	no
Filters	Selectable: disabled, low, medium or high			
Units	Switchable: lb, kg			
Display	Luminosity, 5 settings, 25mm high numeric LED for weight value 9 LEDs to display the status of the crane scale Luminosity may be adjusted in the user menu			
Casing	Zinc coated aluminium casting IP65, silver colour			
Hook and loop	nickel-plated steel			
Power	6V 7Ah rechargeable lead acid battery P65 approx. 300 loading cycles battery charger included: 6.5 V / 0.8			
Operating time	Max. 150 hours between charging			
Working temperature	-10 to +40 °C			
Storage temperature	-30 to +60 °)			
Relative humidity	10 to 85%, non-condensing			
Battery charger	Serially			
Remote control	Serially	Power supply	• 2 AA alkaline batteries	
		Battery change	• After approximately 6 months	

<b>KERN</b>	<b>HTS150K 50IPM</b>	<b>HTS300K 100IPM</b>	<b>HTS600K 200IPM</b>	<b>HTS1.5T 0.5IPM</b>
Readability (d)	50 g	100 g	200 g	500 g
Weighing range (Max)	150 kg	300 kg	600 kg	1500 kg
Taring range (subtractive)	150 kg	300 kg	600 kg	,500 kg
Reproductability	50 g	100 g	200 g	500g
Linearity	± 100 g	± 200 g	± 400 g	± 1000g
Verifiable	yes	yes	yes	yes
Verification value (e)	50 g	100 g	200 g	500 g
Min. charge (Min = 20 d)	1 kg	2 kg	4 kg	10 kg
Accuracy category	III	III	III	III
Filters	Selectable: disabled, low, medium or high			
Units	Switchable: lb, kg			
Display	Luminosity, 5 settings, 25mm high numeric LED for weight value 9 LEDs to display the status of the crane scale Luminosity may be adjusted in the user menu			
Casing	Zinc coated aluminium casting IP65, silver colour			
Hook and loop	nickel-plated steel			
Power	6V 7Ah rechargeable lead acid battery P65 approx. 300 loading cycles battery charger included: 6.5 V / 0.8			
Operating time	Max. 150 hours between charging			
Working temperature	-10 to +40 °C			
Storage temperature	-30 to +60 °C			
Relative humidity	10 to 85%, non-condensing			
Battery charger	Serially			
Remote control	Serially	Power supply	• 2 AA alkaline batteries	
		Battery change	• After approximately 6 months	

## 1.2 Large construction

KERN	HTS3T1IP	HTS6T2IP	HTS10T5IP
Readability (d)	1 kg	2 kg	5 kg
Weighing range (Max)	3 000 kg	6 000 kg	10 000 kg
Taring range (subtractive)	3 000 kg	6 000 kg	7 500 kg
Reproductibility	1 000 g	2 000 g	5 000g
Linearity	±2 000g	±4 000g	±10 000 g
Verifiable	no	no	no
Filters	Selectable: disabled, low, medium or high		
Units	Switchable: lb, kg		
Display	Luminosity, 6 settings, 30 mm high numeric LED for weight value bright, 1-digit, 20 mm high numeric LED for the current accumulator number 9 LEDs to display the status of the crane scale Luminosity may be adjusted in the user menu		
Casing	Zinc coated aluminium casting IP65, silver colour		
Hook and loop	nickel-plated steel		
Power	6V 7Ah rechargeable lead acid battery P65 approx. 300 loading cycles battery charger included: 6.5 V / 0.8		
Operating time	Max. 150 hours between charging		
Working temperature	-10 to +40 °C		
Storage temperature	-30 to +60 °C)		
Relative humidity	10 to 85%, non-condensing		
Battery block	Serially		
Battery charger	Serially		
Remote control	Serially	Power supply	<ul style="list-style-type: none"> <li>• 2 AA alkaline batteries</li> </ul>
		Battery change	<ul style="list-style-type: none"> <li>• After approximately 6 months</li> </ul>

<b>KERN</b>	<b>HTS3T1IPM</b>	<b>HTS6T2IPM</b>	<b>HTS10T5IPM</b>
Readability (d)	1 kg	2 kg	5 kg
Weighing range (Max)	3 000 kg	6 000 kg	10 000 kg
Taring range (subtractive)	3 000 kg	6 000 kg	7 500 kg
Reproductability	1 000 g	2 000 g	5 000g
Linearity	±2 000g	±4 000g	±10 000 g
Verifiable	yes	yes	yes
Verification value (e)	1000 g	2000 g	5000 g
Min. charge (Min = 20 d)	20 kg	40 kg	100 kg
Accuracy category	III	III	III
Filters	Selectable: disabled, low, medium or high		
Units	Switchable: lb, kg		
Display	Luminosity, 6 settings, 30 mm high numeric LED for weight value bright, 1-digit, 20 mm high numeric LED for the current accumulator number 9 LEDs to display the status of the crane scale Luminosity may be adjusted in the user menu		
Casing	Zinc coated aluminium casting IP65, silver colour		
Hook and loop	nickel-plated steel		
Power	6V 7Ah rechargeable lead acid battery P65 approx. 300 loading cycles battery charger included: 6.5 V / 0.8		
Operating time	Max. 150 hours between charging		
Working temperature	-10 to +40 °C		
Storage temperature	-30 to +60 °C		
Relative humidity	10 to 85%, non-condensing		
Battery block	Serially		
Battery charger	Serially		
Remote control	Serially	Power supply	<ul style="list-style-type: none"> <li>• 2 AA alkaline batteries</li> </ul>
		Battery change	<ul style="list-style-type: none"> <li>• After approximately 6 months</li> </ul>

### 1.3 Dimensions

Small construction:

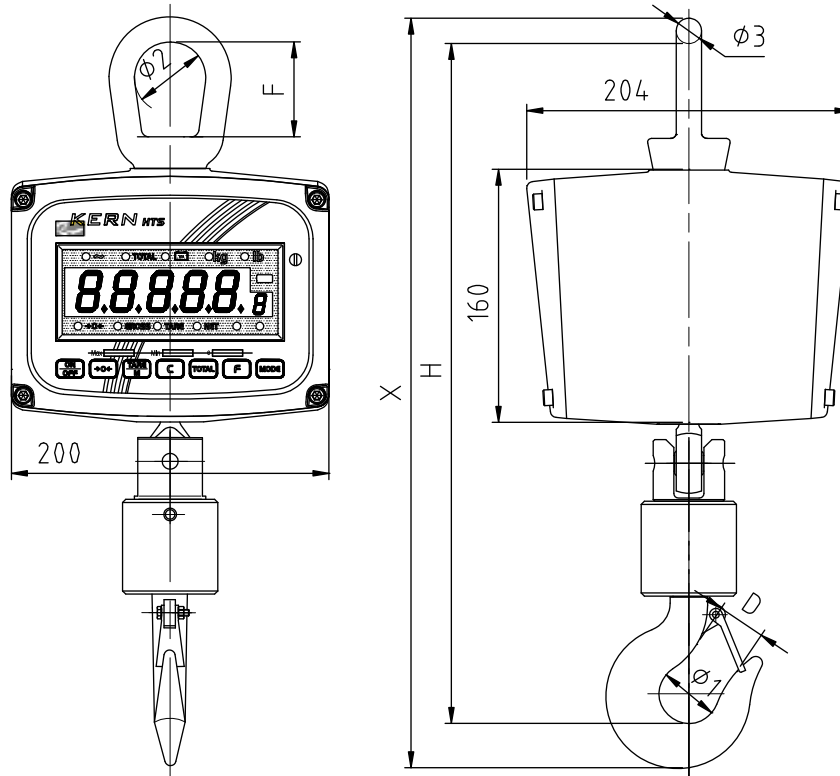

HTS 150kg—600kg

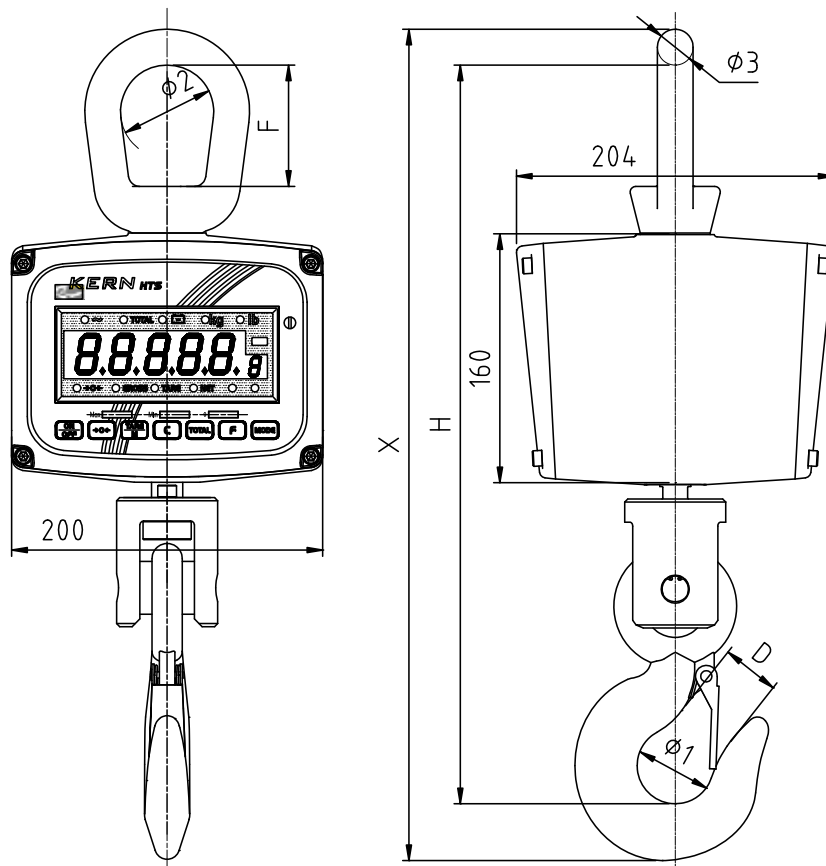

**HTS1.5t**

Model	Dimensions (mm)							Net weight (kg)	Packing	
	D	F	H	Ø1	Ø2	Ø3	X		Gross weight (kg)	L×B×H (mm)
HTS150kg	30	60	435	37.5	45	16	480	12	14	540x270x310
HTS300kg										
HTS600kg										
HTS1.5t	28	78	465	40	60	23	516	13	15	

**Large construction:**

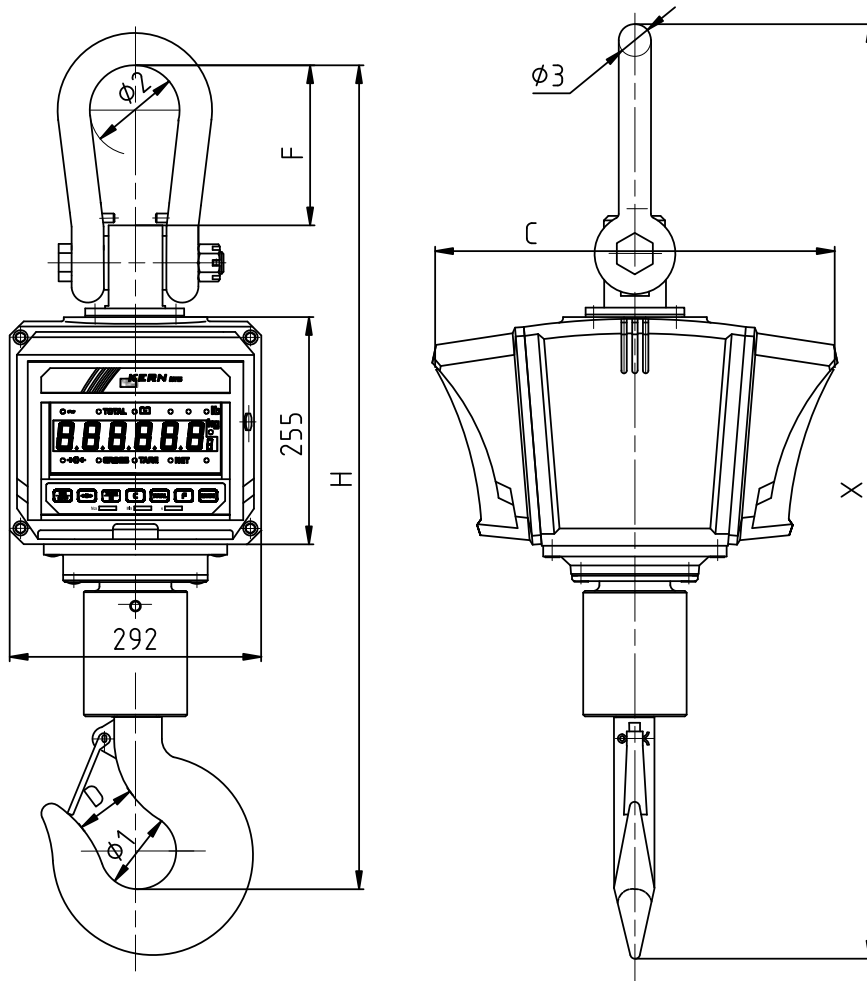

Model	Dimensions (mm)								Net weight (kg) H	Packing	
	D	F	H	D	F	H	D	F		Gross weight (kg)	LxBxH (mm)
HTS3t	380	45	140	735	60	90	28	815	41	46	900x470x400
HTS6t	450	67	185	900	85	100	36	1040	65	73	1140x540x400
HTS10t											

## 2. Declaration of conformity



**KERN & Sohn GmbH**

D-72322 Balingen-Frommern  
Postfach 4052  
E-Mail: [info@kern-sohn.de](mailto:info@kern-sohn.de)

Tel: 0049-[0]7433- 9933-0  
Fax: 0049-[0]7433-9933-149  
Internet: [www.kern-sohn.de](http://www.kern-sohn.de)

## Konformitätserklärung

**EC-Konformitätserklärung**

**EC-Declaration of -Conformity**

**EC- Déclaration de conformité**

**EC-Declaración de Conformidad**

**EC-Dichiarazione di conformità**

**EC-Conformiteitverklaring**

**EC- Declaração de conformidade**

**EC- Prohlášení o shode**

**EC-Deklaracja zgodności**

**EC-Заявление о соответствии**

<b>D</b>	Konformitäts- erklärung	Wir erklären hiermit, dass das Produkt, auf das sich diese Erklärung bezieht, mit den nachstehenden Normen übereinstimmt.
<b>GB</b>	Declaration of conformity	We hereby declare that the product to which this declaration refers conforms with the following standards.
<b>CZ</b>	Prohlášení o shode	Tímto prohlašujeme, že výrobek, kterého se toto prohlášení týká, je v souladu s níže uvedenými normami.
<b>E</b>	Declaración de conformidad	Manifestamos en la presente que el producto al que se refiere esta declaración está de acuerdo con las normas siguientes.
<b>F</b>	Déclaration de conformité	Nous déclarons avec cela responsabilité que le produit, auquel se rapporte la présente déclaration, est conforme aux normes citées ci-après.
<b>I</b>	Dichiarazione di conformità	Dichiariamo con ciò che il prodotto al quale la presente dichiarazione si riferisce è conforme alle norme di seguito citate.
<b>NL</b>	Conformiteit- verklaring	Wij verklaren hiermede dat het product, waarop deze verklaring betrekking heeft, met de hierna vermelde normen overeenstemt.
<b>P</b>	Declaração de conformidade	Declaramos por meio da presente que o produto no qual se refere esta declaração, corresponde às normas seguintes.
<b>PL</b>	Deklaracja zgodności	Niniejszym oświadczamy, że produkt, którego niniejsze oświadczenie dotyczy, jest zgodny z poniższymi normami.
<b>RUS</b>	Заявление о соответствии	Мы заявляем, что продукт, к которому относится данная декларация, соответствует перечисленным ниже нормам.

## Electronic Crane Scale: HTS

Mark applied	EU Directive	Standards	Approval/ Test-certificate N°
<b>CE</b>	2006/95/EC Low Voltage Directive	EN 60950-1 : 2006	
<b>CE</b>	2004/108/EC EMC Directive	EN61326-1: 1997 +A1: 1998+A2: 2001 (Class B)	
<b>CE</b>	2006/42/EC Machine directive	EN13155: 1998 (2)	
<b>CE</b> year 1259 <b>M</b>	90/384/EEC Non-automatic Weighing Instruments Directive	EN45501 1)	T6778 1)

1) gilt nur für geeichte Waagen  
valable uniquement pour les balances vérifiées  
la dichiarazione vale solo per le bilance omologate  
vale só para balanças com aferição  
dotyczy tylko wag legalizowanych

applies only to certified balances  
sólo aplicable a balanzas verificadas  
Geldt uitsluitend voor geijkte weegschalen  
platí jen pro cejchované váhy  
действует только для поверенных весов

**Date: 17.09.2009**

**Signature:**













**Gottl. KERN & Sohn GmbH**

**Management**

Gottl. KERN & Sohn GmbH, Ziegelei 1, D-72336 Balingen, Tel. +49-[0]7433/9933-0, Fax +49-[0]7433/9933-149

<b>English</b>	<b>Important notice for verified weighing instruments</b>
	Weighing instruments verified at the place of manufacture bear the preceding mark on the packing label and a green M-sticker on the descriptive plate. They may be set to work immediately.
	Weighing instruments which are verified in two steps has no green "M" on the descriptive plate, bear the aforementioned identification on the packing label. The second step of the verification must be carried out by the W&M authorities
	The first step of the verification has been carried out at the manufacturing plant. It comprises all tests according to EN 45501-8.2.2. If national regulations in individual countries limit the period of validity of the certification, the operator of such a scale is himself responsible for its timely re-certification.
<b>Deutsch</b>	<b>Wichtiger Vermerk für geeichte Waagen in EU-Ländern</b>
	Werksgeeichte Waagen tragen vorstehendes Kennzeichen auf dem Packetikett und eine grünen M-Kleber auf dem Eichschild. Sie dürfen sofort in Betrieb genommen werden.
	Waagen die in zwei Schritten geeicht werden und kein grünes "M" auf dem Eichschild haben, tragen vorstehendes Kennzeichen auf dem Packetikett. Der zweite Schritt der Eichung ist durch den Eichbeamten durchzuführen.
	Der erste Schritt der Eichung wurde im Herstellerwerk durchgeführt. Er umfasst alle Prüfungen gemäß EN45501-8.2.2. Sofern gemäß den nationalen Vorschriften in den einzelnen Staaten die Gültigkeitsdauer der Eichung beschränkt ist, ist der Betreiber einer solchen Waage für die rechtzeitige Nacheichung Selbst verantwortlich.
<b>Français</b>	<b>Remarque importante pour les Instruments de pesage vérifiées dans les pays membre de l'Union Européenne</b>
	Les instruments de pesage vérifiés en usine sont identifiés par un M sur leur emballage et par un sticker M vert sur la plaque d'identification. Ils peuvent être utilisés après leur installation.
	Les instruments de pesage vérifiés en deux étapes portent l'identification M barré sur leur emballage. La seconde étape de la vérification doit être effectuée par l'assistant technique de l'administration des poids et mesures.
	La première étape de la vérification a été effectuée en usine. Cela comprend tous les essais suivant la norme EN45501-8.2.2. Dans la mesure où la durée de la vérification est limitée en fonction des prescriptions nationales dans les différents pays, l'utilisateur d'une telle balance est lui-même responsable de la vérification ultérieure dans les délais.
<b>Español</b>	<b>Nota importante para balanzas verificadas en paises de la UE</b>
	Las balanzas verificadas en origen llevan esta indicación en la etiqueta del embalaje y con la etiqueta M sobre fondo verde en la placa de características pueden ser utilizadas inmediatamente.
	Balanzas cuya verificación se realiza en dos fases llevan esta indicación en la etiqueta del embalaje. La segunda fase de la verificación debe ser realizada por el asistente técnico de la oficina de contraste.
	La primera fase de la verificación ha sido realizada en origen. Incluye todos los ensayos según lo norma EN45501-8.2.2. Si el plazo de validez de la verificación está limitado por las normas nacionales de cada estado, el usuario será responsable de las verificaciones posteriores reglamentarias de su balanza.
<b>Italiano</b>	<b>Nota importante per la bilance approvate nei paesi UE</b>
	Le bilance verificate in fabbrica portano questo contrassegno sull'etichetta dell'imballo e con il sigillo M su sfondo verde sulla targhetta metrologica possono essere messe in uso immediatamente.
	Le bilance che vengono verificate in due fasi, portano questo contrassegno sull'etichetta dell'imballo. La seconda fase della verifica deve essere eseguita dal servizio assistenza tecnica dell'ufficio di pesi e misure.
	La prima fase della verifica è stata eseguita dal produttore e comprende tutte le prove previste dalla norma EN 45501-8.2.2. Se la durata di validità della verifica è limitata in accordo con le prescrizioni nazionali vigenti nei singoli paesi, l'utente stesso di una bilancia di tale tipa sarà responsabile dell'esecuzione, entro le date di scadenza previste, delle verifiche periodiche.

<b>Netherlands Belangrijke aanmerking voor geijkte weegschalen in EG-landen</b>	
	In de fabriek geijkte weegschalen dragen dit kenteken op het emballage-etiket en een groene M-sticker op het ijklabel. Deze kunnen meteen in gebruik genomen worden.
	Bij weegschalen die in twee stappen geijkt moeten worden en geen groene "M" op het ijklabel hebben, staat dit kenteken op het emballage-etiket. De tweede stap van de ijking moet door het ijkwezen uitgevoerd worden.
De eerste stap van de ijking werd in de fabriek doorgevoerd. Deze omvat alle inspecties conform EN45501-8.2.2. Voor zover in overeenstemming met de nationale voorschriften in de individuele staten de geldigheidsduur van de ijking beperkt is, is de exploitant van een dergelijke weegschaal voor een tijdige herijking zelf verantwoordelijk.	
De eerste stap van de ijking werd in de fabriek uitgevoerd. Deze stap omvat alle tests overeenkomstig EN45501-8.2.2. Bij weegschalen met een analoge weegbruggeaansluiting moet aanvullend de nauwkeurigheid overeenkomstig EN45501-3.5.3.3 getest worden. Deze controle is niet nodig als de terminal het serienummer van de weegbrug heeft.	
<b>Português Nota importante para as balanças aferidas em países EU</b>	
	As balanças aferidas pela fábrica levam o cartaz identificador sobre a etiqueta de pacote e um adesivo M verde sobre a placa de aferição. Têm que colocar-se em funcionamento sem demora.
	As balanças que foram aferidas em dois passos e que não tenham um "M" verde sobre a placa de aferição, têm o rótulo antecedente na etiqueta de pacote. O segundo passo da aferição tem que ser feito por um empregado público de aferição.
A primeira fase da aferição foi feita na fábrica do produtor. Abrange todas as inspeções segundo EN45501-8.2.2. Logo que segundo as normas nacionais nos estados individuais a duração de validade da aferição esteja limitada, o usuário-proprietário duma tal balança é mesmo responsável pela aferição posterior a tempo.	
<b>Česky Důležitý pokyn pro cejchované váhy v zemích EU</b>	
	Váhy ocejchované ve výrobním závodě jsou opatřeny výše uvedenou značkou na etiketě balení a zelenou nálepkou M na cejchovacím štítku. Takže se mohou okamžitě uvést do provozu.
	Váhy se cejchují ve dvou etapách, a jestliže nemají zelené M na cejchovacím štítku, mají na etiketě balení výše uvedenou značku. Druhou etapu cejchování provádí cejchovní úřad.
První fáze cejchování byla provedena ve výrobním závodě. Zahrnuje všechny testy podle EN45501-8.2.2. Pokud je podle národních předpisů v jednotlivých státech omezená časová platnost cejchování, je provozovatel takových vah sám odpovědný za včasné přecejchování.	
<b>Polski Adnotacje dotyczące legalizowanych wag w państwach UE</b>	
	Legalizowane u producenta wagi mają wystające oznaczenie na opakowaniu i zieloną nalepkę M na znaku legalizacji. Takie wagi można natychmiast eksploatować.
	Wagi, które są legalizowane w dwóch etapach i nie mają zielonego „M” na znaku legalizacji, mają wystające oznaczenie na etykietce opakowania. Drugi etap legalizowania musi przeprowadzić pracownik urzędu miar i wag.
Pierwszy etap legalizowania przeprowadzono w zakładzie producenta. Obejmuje wszystkie kontrole według EN45501-8.2.2. Jeśli okres ważności legalizacji wagi jest ograniczony zgodnie z narodowymi przepisami obowiązującymi w poszczególnych państwach, użytkownik ponosi wyłączną odpowiedzialność za przeprowadzenie w odpowiednim czasie ponownej legalizacji wagi.	
<b>Русски Примечание для поверенных весов в странах ЕЭС</b>	
	Поверенные на заводе весы помечаются вышеуказанным символом на упаковочной этикетке и зеленой наклейкой "М" на табличке поверки. Они могут немедленно приниматься в эксплуатацию.
	Весы, которые поверяются в два этапа и не имеют зеленой наклейки "М" на табличке поверки, помечаются вышеуказанным символом на упаковочной этикетке. Второй этап поверки должен производиться поверочным ведомством.
Первый шаг поверки был выполнен на заводе-изготовителе. Он включает все проверки согласно EN45501-8.2.2. Если в соответствии с национальными предписаниями отдельных государств срок действия поверки ограничен, эксплуатирующая организация сама несет ответственность за своевременную повторную поверку таких весов.	

### **Notice**

Certified balances and balances used for legal applications have the EU type approval. The year of the initial verification is shown next to the CE mark. Such balances are verified in the factory and carry the „M“ mark on the actual balance and the packaging. The year of initial verification is shown next to the CE mark. The GEO value of verified balances explains for which location of use the balance has been verified. This GEO value is shown on the balance itself and on the packing. Further details see GEO value table.

### **Hinweise**

Für geeichte/eichpflichtige Waagen liegt eine EU Bauartzulassung vor. Das Jahr der ersten Eichung ist neben dem CE Zeichen aufgeführt. Solche Waagen sind ab Werk geeicht und tragen die Kennzeichnung „M“ auf dem Gerät selbst und auf der Verpackung. Der GEO-Wert gibt bei vom Hersteller geeichten Waagen an, für welchen Aufstellungsort die Waage geeicht ist. Dieser GEO-Wert befindet sich auf der Waage sowie der Verpackung. Genaueres ist der GEO-Wert-Tabelle zu entnehmen.

### **Remarques**

Les balances vérifiées/admissibles à la vérification font l'objet d'une approbation de modèle UE. L'année de la vérification primitive est indiqués à côté de la marque CE. Ces balances sont vérifiées d'origine et portent la marque „M“ sur l'appareil lui-même et sur l'emballage. Le valeur GEO indique le lieu d'utilisation pour lequel la balance été vérifiée. Ce valeur GEO se trouve sur la balance ainsi que sur l'emballage. Veuillez trouver plus de détails dans le tableau GEO.

### **Notas**

Las balanzas verificadas/verificables cuentan con una aprobación de modelo UE. El año de la primera verificación está indicado al lado del distintivo CE. Estas balanzas están verificadas en fábrica y llevan la designación „M“ sobre el propio aparato y sobre el embalaje. El valor GEO indica el lugar de ubicación por lo cual la balanza está verificado. El valor se encuentra sobre la balanza así como sobre el embalaje. Por favor tomen los demás detalles de la tabla GEO.

### **Avvertenza**

Per le bilance approvate esiste un'approvazione CE del tipo. L'anno della prima verifica è indicato a fianco della marcatura CE. I tipi marcati con un contrassegno „M“ su sfondo verde possono essere impiegati da subito. Il coefficiente GEO di bilance omologate indica per quale luogo la bilancia è stata omologata. Questo coefficiente GEO si trova sulla bilancia e sull'imballo. Ulteriori informazioni vedi tabella coefficiente GEO

### **Opmerkingen**

Voor geijkte weegschalen/weegschalen, die verplicht geijkt moeten worden, ligt er een EG-modelgoedkeuring ter inzage. Het jaar van de eerste ijking werd naast het EG-conformiteitsteken vermeld. Dergelijke weegschalen werden in de fabriek geijkt en dragen het identificatielabel „M“ op het apparaat zelf en op de verpakking. De GEO-waarde geeft bij door de fabrikant geijkte weegschalen aan, voor welke plaats van opstelling de weegschaal geijkt is. Deze GEO-waarde bevindt zich op de weegschaal en ook op de verpakking. Meer details kan er uit de tabel met de GEO-waarde afgeleid worden.

### **Instruções**

Para as balanças aferidas / obrigadas à aferição existe uma homologação de tipo construtivo da EU. O ano da primeira aferição fica ao lado do símbolo CE. Tais balanças foram aferidas na fábrica e levam o rótulo „M“ no mesmo aparelho e na embalagem. O valor GEO indica nas balanças aferidas pelo produtor para qual lugar de colocação a balança foi aferida. Este valor GEO encontra-se na balança assim como na embalagem. Mais pormenores podem ver-se na tabela dos valores GEO.

### **Poznámky**

Pro ocejchované a cejchování podléhající váhy existuje povolení EU podle typu konstrukce. Rok prvního cejchování se uvádí vedle značky CE. Takové váhy se cejchují ve výrobním závodě, a jsou označeny znakem „M“ na vlastním přístroji, i na obalu. Hodnota GEO udává u výrobcem cejchovaných vah, pro jaké místo instalace je váha ocejchována. Tato hodnota GEO se nachází na váze, jakož i na obalu. Přesnější je odečíst hodnotu GEO z tabulky.

### Wskazówki

Dla wag legalizowanych/podlegających obowiązkowi legalizowania istnieje dokument dopuszczenia rodzaju konstrukcji UE. Rok pierwszej legalizacji jest podany obok znaku CE. Takie wagi są legalizowane w zakładzie producenta i mają oznaczenie „M” na sobie i na opakowaniu. W przypadku wag legalizowanych u producenta wartość geograficzna podaje, dla jakich miejsc ustawienia waga została legalizowana. Ta wartość geograficzna znajduje się zarówno na wadze jak i na opakowaniu. Dokładne informacje znajdują się w tabeli wartości geograficznych.

### Указания

Калиброванные/подлежащие поверке весы получают допуск на конструкцию ЕС. Год первой поверки приведен рядом с символом CE. Такие весы поверены на заводе и имеют маркировку „M” на самом устройстве и на упаковке. Значение GEO на откалиброванных изготовителем весов указывает, для какого места установки произведена калибровка весов. Это значение GEO находится на весах и на упаковке. Более подробная информация содержится в таблице значений GEO

### GEO-WERT-Tabelle / GEO-value table

geographische Breite /geo- graphical latitude				Höhe über Meer in Metern / altitude					
				0-650	650-1300	1300-1950	1950-2600	2600-3250	
0°	0'	-	9°	52'	4 / 5	3 / 4	2 / 3	1 / 2	0 / 1
9°	52'	-	15°	6'	5 / 6	4 / 5	3 / 4	2 / 3	1 / 2
15°	6'	-	19°	2'	6 / 7	5 / 6	4 / 5	3 / 4	2 / 3
19°	2'	-	22°	22'	7 / 8	6 / 7	5 / 6	4 / 5	3 / 4
22°	22'	-	25°	21'	8 / 9	7 / 8	6 / 7	5 / 6	4 / 5
25°	21'	-	28°	6'	9 / 10	8 / 9	7 / 8	6 / 7	5 / 6
28°	6'	-	30°	41'	10 / 11	9 / 10	8 / 9	7 / 8	6 / 7
30°	41'	-	33°	9'	11 / 12	10 / 11	9 / 10	8 / 9	7 / 8
33°	9'	-	35°	31'	12 / 13	11 / 12	10 / 11	9 / 10	8 / 9
35°	31'	-	37°	50'	13 / 14	12 / 13	11 / 12	10 / 11	9 / 10
37°	50'	-	40°	5'	14 / 15	13 / 14	12 / 13	11 / 12	10 / 11
40°	5'	-	42°	19'	15 / 16	14 / 15	13 / 14	12 / 13	11 / 12
42°	19'	-	44°	32'	16 / 17	15 / 16	14 / 15	13 / 14	12 / 13
44°	32'	-	46°	45'	17 / 18	16 / 17	15 / 16	14 / 15	13 / 14
46°	45'	-	48°	58'	18 / 19	17 / 18	16 / 17	15 / 16	14 / 15
48°	58'	-	51°	13'	19 / 20	18 / 19	17 / 18	16 / 17	15 / 16
51°	13'	-	53°	31'	20 / 21	19 / 20	18 / 19	17 / 18	16 / 17
53°	31'	-	55°	52'	21 / 22	20 / 21	19 / 20	18 / 19	17 / 18
55°	52'	-	58°	17'	22 / 23	21 / 22	20 / 21	19 / 20	18 / 19
58°	17'	-	60°	49'	23 / 24	22 / 23	21 / 22	20 / 21	19 / 20
60°	49'	-	63°	30'	24 / 25	23 / 24	22 / 23	21 / 22	20 / 21
63°	30'	-	66°	24'	25 / 26	24 / 25	23 / 24	22 / 23	21 / 22
66°	24'	-	69°	35'	26 / 27	25 / 26	24 / 25	23 / 24	22 / 23
69°	35'	-	73°	16'	27 / 28	26 / 27	25 / 26	24 / 25	23 / 24
73°	16'	-	77°	52'	28 / 29	27 / 28	26 / 27	25 / 26	24 / 25
77°	52'	-	85°	45'	29 / 30	28 / 29	27 / 28	26 / 27	25 / 26

### **3. General Safety Instructions**

#### **Duties of the owner-operator**

- Adhere to national accident prevention prescriptions and the operator's work, operating and safety prescriptions.
- Adhere to all of the crane manufacturer's safety prescriptions.
- The scale must only be used for the intended purpose. Any type of use which is not described in these operating instructions is regarded as improper use. The owner takes full responsibility for material damage and personal injury which is a result of such improper use. KERN & Sohn take no responsibility whatsoever. KERN & Sohn cannot be made liable, if the crane scale is altered or used improperly, and if damage occurs because of this.
- You must service and maintain the crane scale, crane and load support regularly (see chapter 10).
- Record test results and keep in test book.

#### **Organizational measures**

- Only trained and instructed persons may operate the appliance.
- Make sure that the instruction manual is always available on the installation site of the crane.
- Have installation, commissioning, maintenance and repairs carried out by specially trained personnel only.
- Repairs must only be carried by service partners authorised by KERN.
- Only use original replacement parts.
- All repairs and replacement parts must be documented by the service partner (see list, chapter 11.3).
- All service work must be documented (see checklist, chapter 10.2).

#### **Environmental conditions**

- Never operate the crane scale in explosion hazard areas. The standard model is not explosion-proof.
- Crane scales must only be installed in the conditions as described in these operating instructions (see chapter 1, "Technical Specifications").
- Do not expose the crane scale to high levels of humidity. Unauthorised levels of condensation (condensation of air moisture on the equipment) can occur, if a cold unit is moved to a significantly warmer environment. In this situation, acclimatise the unit for approximately 2 hours at room temperature. Make sure the equipment is not connected to the mains at that time.
- Do not use the crane scale in a corrosive atmosphere.
- Protect the crane scale from high levels of air humidity, vapours, liquids and dust;

**Intended use**

- Use the crane scale exclusively for lifting and weighing freely moveable loads.
- Failure to adhere to prescriptions when using the appliance may result in injury. For example, the following is not permitted:
  - exceeding the permissible nominal load of the crane, crane scale or any type of load attachment equipment,
  - transporting persons,
  - pulling loads at an angle,
  - tearing loose, pulling or dragging loads.
- Changes or modifications to the crane scale or the crane are not permitted.

**Safety conscious working methods**

- Do not stop under suspended loads.
- Only position the crane so that the load is lifted vertically.
- Wear personal safety equipment (helmet, safety gloves) when working with the crane and crane scale.

**Decommissioning and storage**

- Remove the crane scale from the crane and remove all load attachment equipment from the crane scale.
- Do not store the crane scale outside
- Remove battery block (large construction) from the crane scale if the crane scale is out of use for an extended period of time.

## 4. Crane scale at a glance

The crane scale is a versatile and economic solution for overhead material handling and weighing applications, i.e. recycling, metal works, machine repair and rebuilding, transport and logistics.

Optional infrared remote control makes operation even easier.

### 4.1 Overview

**Small construction:**

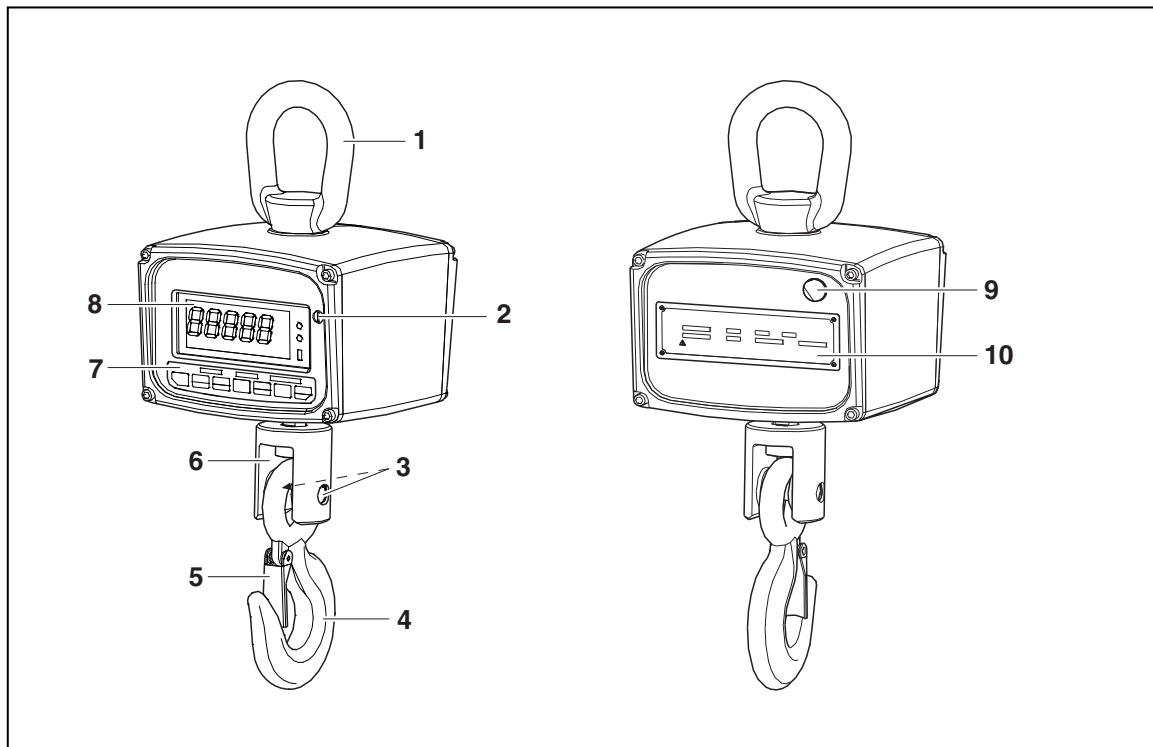

- |   |                          |    |                                   |
|---|--------------------------|----|-----------------------------------|
| 1 | Eye                      | 6  | Connecting pipe                   |
| 2 | Gauge propeller          | 7  | Keyboard                          |
| 3 | Retaining pins (2 items) | 8  | Display                           |
| 4 | Hook                     | 9  | Cover battery charging connection |
| 5 | Safety clip              | 10 | Nameplate                         |

**Large construction:**

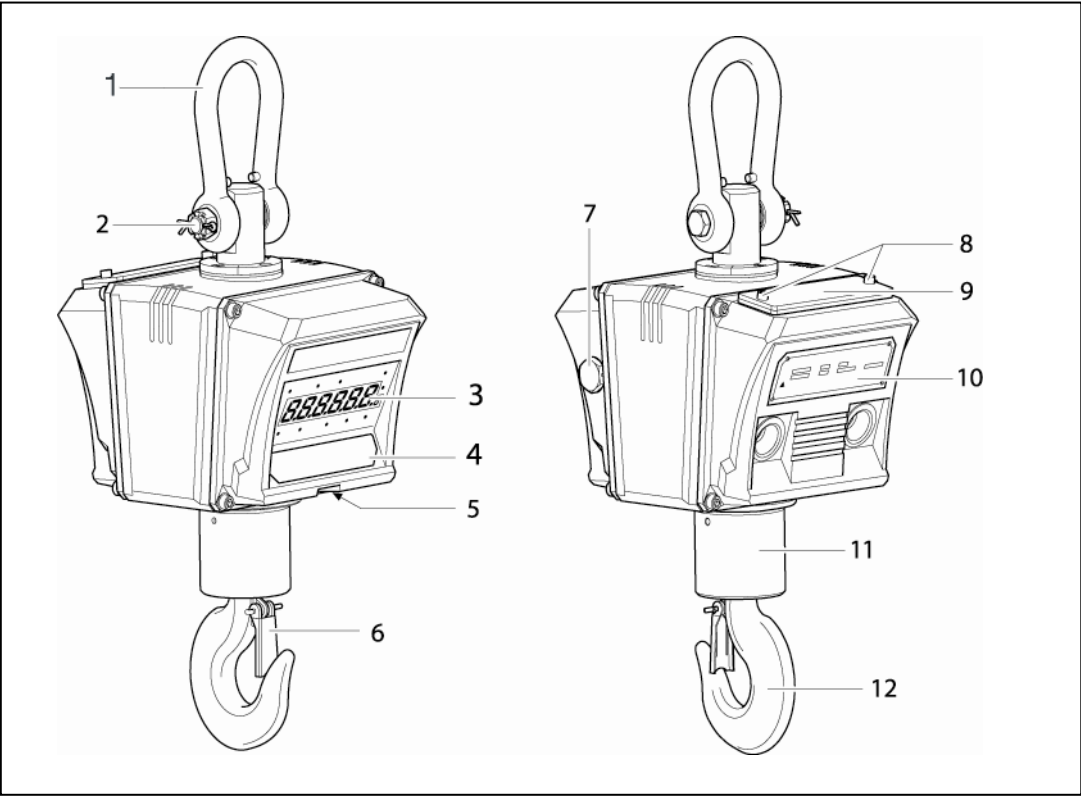

- 1 Eye
- 2 Splint
- 3 Display
- 4 Keyboard
- 5 Window for IR remote control
- 6 Safety clip
- 7 Gauge propeller
- 8 Battery screw
- 9 Battery and battery cover
- 10 Nameplate
- 11 Swivel joint
- 12 Hook

## 4.2 Display

### Small construction:

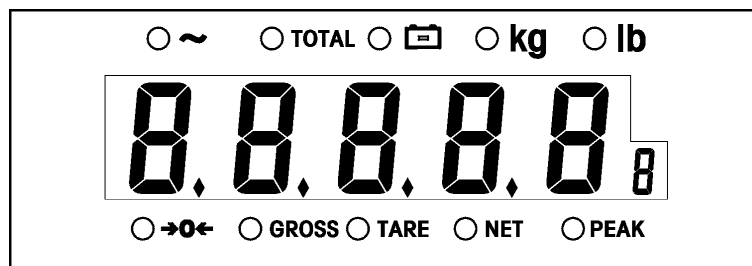

The weight display is a 5 digit LED display.

### Large construction:

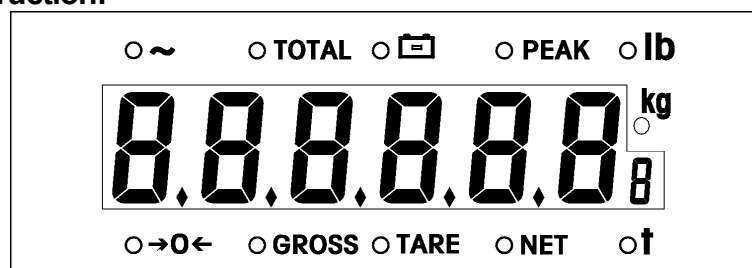

The weight display is a 6 digit LED display (big numbers). The small number on the right hand side indicates the current accumulator number.

LED	Meaning	The LED will illuminate when ...
~	Movement	The scale is in motion
Total	Total	the scale adds a new value into the totals memory or The display shows the accumulated weight or the number of posts
BAT	BAT low	Battery falls below a certain value
kg		The weight unit currently shown is Kg
lb		The weight unit currently shown is lb
t large construction only		the current displayed weight unit is t
→0←	Zero	Weight is approximately +/- ¼ d around the zero point
Gross	Gross	The scale shows the gross weight
Tare	Tare	The scale shows the tare weight
Net	Net	The scale shows the net weight
PEAK		the scale displays the highest load value of a weighing (peak value)

### 4.3 Keyboard

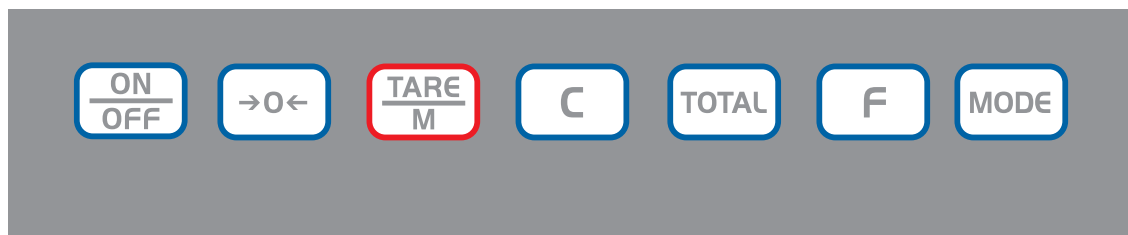

Key	Meaning	Functional Description
<b>On/Off</b>	On / Off	Switches the scale on or off...
<b>→0←</b>	Zero / master	Corrects the zero point of the scale The display is set to zero.  Only use this key in gross mode.
<b>TARE/M</b>	Tare/M	In gross mode this button saves the current weight value as tare weight. The scale will display the net weight 0
<b>C</b>	Delete	In net mode: the scale returns to gross mode  In gross mode: the scale starts a self-test  In weight hold mode: the scale returns to weighing mode
<b>TOTAL</b>	Amount / maximum	The current weight value is added to the amount memory, the Total LED will blink for 3 seconds.
<b>F</b>	Call / stop	<b>In Hold mode:</b> The scale displays the most recently-stored peak value  <b>In Net and Gross mode:</b> The scale displays the tare weight.  <b>In Totals mode:</b> When pressed repeatedly the crane scale displays the tare value, the accumulated value, the number of items and the gross value.
<b>MODE + →0←</b>		Access user menu to set parameters, see chapter 7
<b>MODE + TARE/M</b>		Checks, saves and calls up the tare weight
<b>MODE + TOTAL</b>		The heaviest load of the last weighings shall be shown
<b>MODE + F</b>		A stable weight value shall be maintained (frozen)

#### 4.4 Remote control

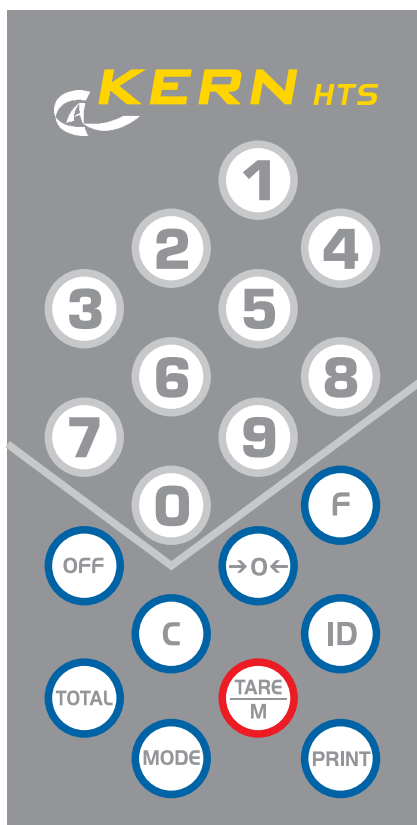

The infra-red remote control can operate the scale as the keyboard does. In addition the remote control adds 10 numerical keys: 0 to 9.

The red LED lights every time a key is pressed.

## 5. Commissioning

### 5.1 Unpacking (large construction)

 <p><b>CAUTION</b></p>	<p><b>Risk of straining your back!</b> <b>The crane scale is compact and relatively heavy.</b></p> <ul style="list-style-type: none"><li>⇒ Remove the scale from the shipping container only with assistance of another person.</li><li>⇒ Use a power-lifting device such as a crane or forklift.</li><li>⇒ Secure the scale to ensure it doesn't drop when lifting.</li></ul>
---	--

### 5.2 Unpacking (large and small construction)

⇒ Ensure that the all parts are accounted for.

- Crane scale
- Battery charger
- Remote control
- Operating Instructions

### 5.3 Checking the original dimensions

- ⇒ Carry out all safety checks, see chapter 10.1 "Regular maintenance after 3 months of operation".
- ⇒ Enter all information (date, examiner, results) in the first line under "Checking before first use" on the checklist (see chapter 10.2)
- ⇒ If the dimensions of your first safety check do not match those of the manufacturer, then the scale must not be used. In this situation, contact a service partner authorised by KERN.

## 5.4 Recharge the battery

A sealed, rechargeable lead-acid battery powers the crane scale.

 <p><b>CAUTION</b></p>	<p><b>Damage to the crane scale!</b></p> <ul style="list-style-type: none"><li>⇒ Only use the battery charger provided with the crane scale.</li><li>⇒ Check that battery charger, cables and mains plug are in good order and condition.</li><li>⇒ Do not use the crane scale while charging.</li></ul>
---	--

### Loading (small construction)

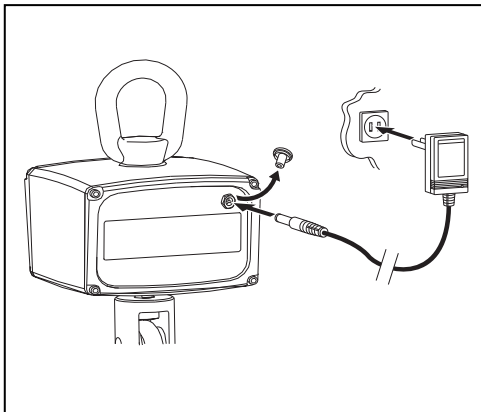

1. Take off the loader connector cover at the back of the crane scale.
2. Connect the battery charger on the one end to the battery pack connector and on the other end to the power outlet (mains). During the charging process, 1 green LED will be lit on the battery charger.
3. The battery is completely charged when both green LEDs on the battery charger are lit. The battery charges completely in 15 hours.

## Loading (large construction)

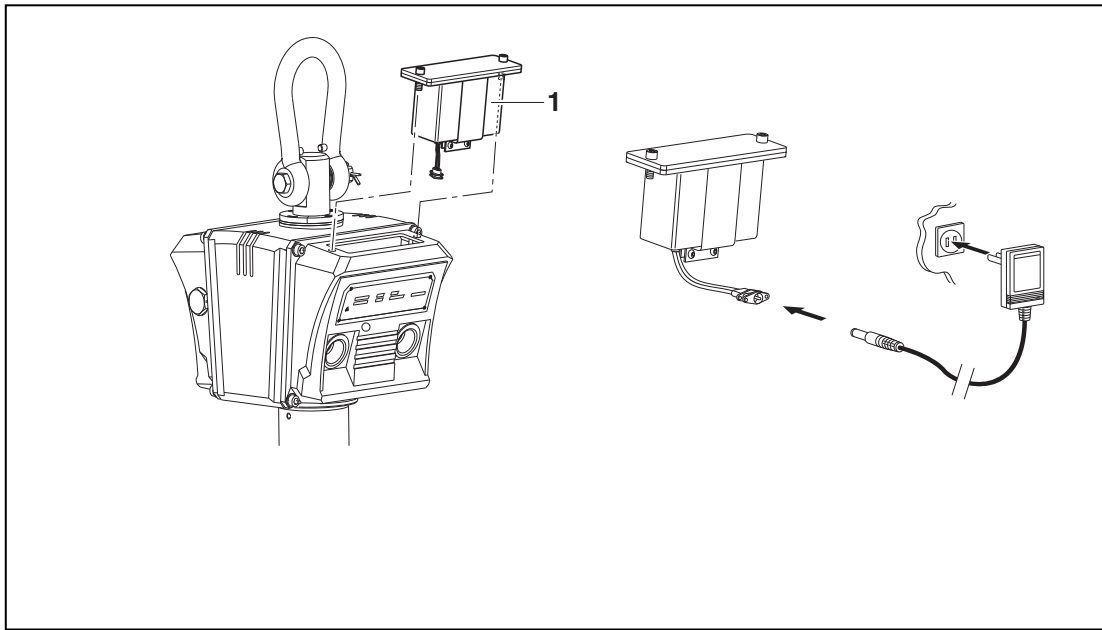

1. Undo the 2 screws of the battery cover on top of the crane scale and pull out the battery pack (1).
2. Unplug the battery pack from the connector in the housing.
3. Connect the battery charger on the one end to the battery pack connector and on the other end to the power outlet (mains).

During the charging process, 1 green LED will be lit on the battery charger.

4. The battery is completely charged when both green LEDs on the battery charger are lit.

The battery charges completely in 15 hours.

## 5.5 Suspend scale

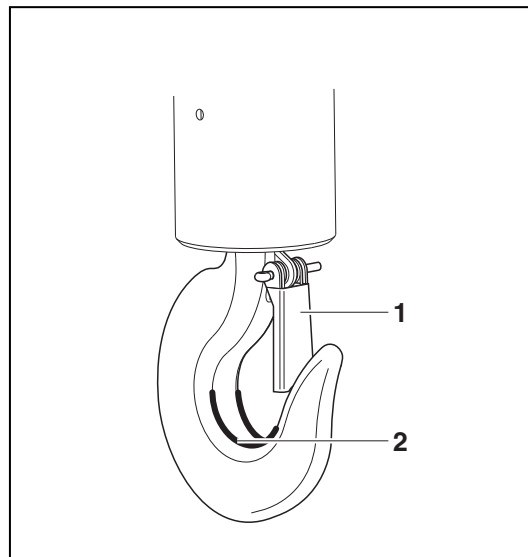

### **Pre-condition**



Your crane must have a safety latch (1) to prevent the crane scale from falling when there is no load.

If there is no safety latch or the safety latch is damaged, please contact the crane manufacturer to obtain a hook with this safety feature.

- ⇒ Hang the crane scale from the bottom hook of a crane and lock the secure latch. The crane scale's upper shackle should rest in the saddle (2).

## 6. Operation

### 6.1 Safety instructions

	<p> <b>Danger</b></p> <p><b>Risk of injury due to falling loads!</b></p> <ul style="list-style-type: none"><li>⇒ Always operate with great care according to the general rules for operating a crane, see chapter 1.</li><li>⇒ Never walk or stand under hanging loads.</li><li>⇒ Do not exceed the rated load capacity of the crane, crane scale or any load bearing item attached to the crane scale.</li><li>⇒ Check all parts (hook, loop, rings, rope loops, cables, chains, etc.) for excessive wear or damage</li><li>⇒ If there are visible defects on the safety latch of the hook, or if it is missing altogether, the scale must not be used.</li><li>⇒ Only work at the appropriate speed</li><li>⇒ You must avoid oscillations and horizontal force. Avoid any type of impacts, twisting (torsion) and oscillations (e.g. caused by suspending at an angle).</li><li>⇒ Do not use crane scale for transporting loads</li></ul>
---	--

### 6.2 Load the crane scale

For good weighing results note the following, for figures see next page:

- ⇒ Do use hardware that creates single point attachments and allows the scale freedom of alignment.
- ⇒ Do not use oversize interface hardware which restricts single point loading.
- ⇒ Do not use multiple attachments.
- ⇒ Do not push or pull the load or the loaded scale.
- ⇒ Do not pull laterally on the hook.

#### Loading the scale

1. Position the crane scale hook over the load.
2. Lower the crane scale until the load can be attached to the scale hook. Reduce speed when reaching the appropriate level.
3. Attach the load to the hook. Make sure that the scale hook latch is closed. If slings are used to handle the load, make sure that the slings are fully seated in the saddle of the scale hook.
4. Start lifting the load slowly.

If slings are used to handle the load, make sure that the load is properly balanced and that the slings are positioned properly.

**Loading small construction:**

**Do use hardware that creates single point attachments and allows the scale freedom of alignment**

**Do not push or pull**

**Do not pull laterally on the hook**

**Do not use oversize interface hardware which restricts single point loading**

**Do not use mutiple attachments**

**Loading large construction:**

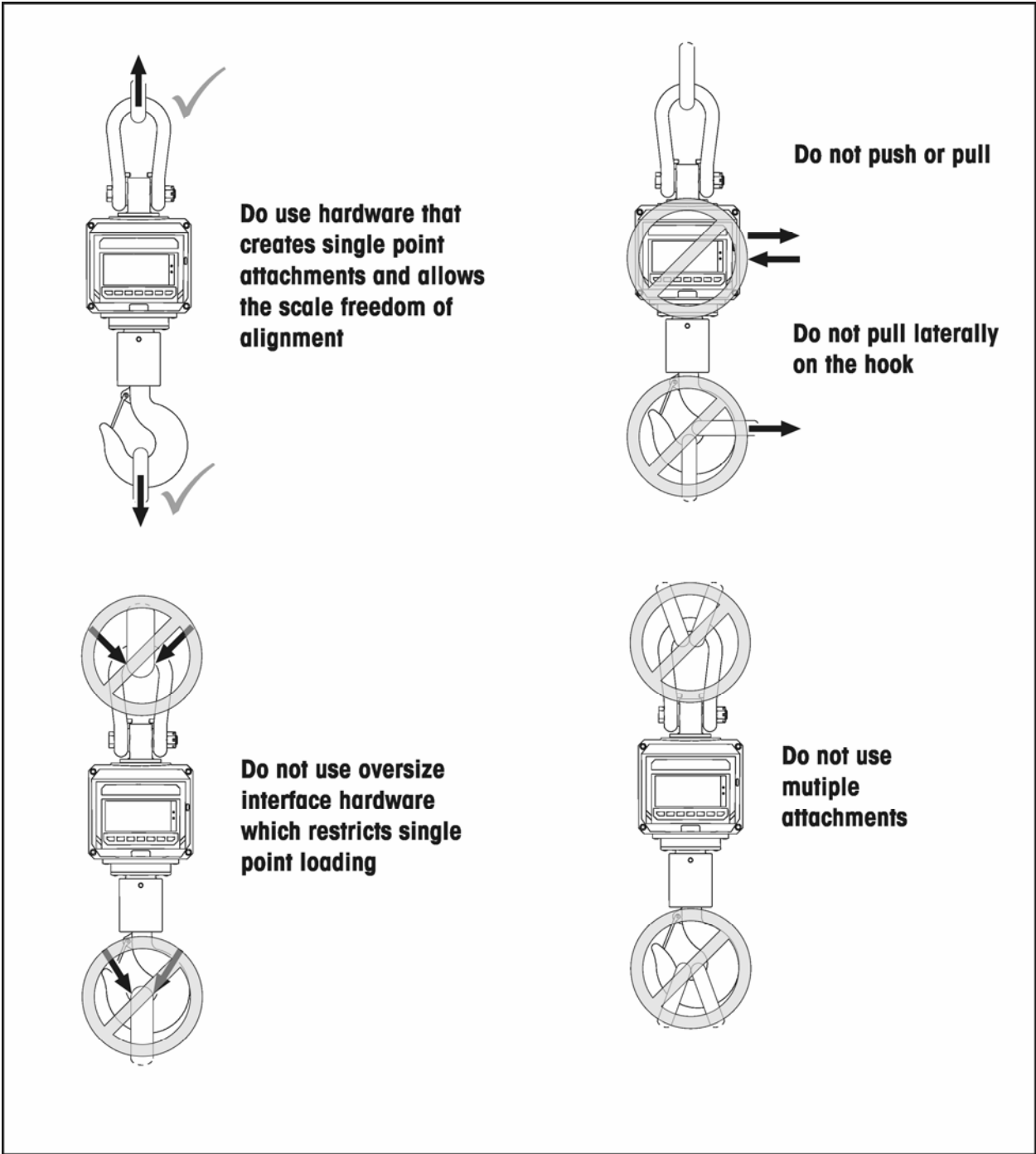

## 6.3 Turn on/off

### Switching on

- ⇒ Press and hold the **On/Off** key on the keyboard of the scale.  
The display illuminates and the scale runs a self test.

The self test is complete when weight value 0 is shown on the display. The crane scale works in gross mode.

#### Note:

Switching on is only possible via the keyboard of the scale.

### Switching Off

- ⇒ Press and hold the **On/Off** key on the keyboard of the scale.
- or
- ⇒ Press the **Off** key on the remote control.

## 6.4 Resetting the scale

For best weighing results set the empty scale to zero before weighing.

Resetting is only possible if the weight value shown is within the preset zero area (see user menu, chapter 8.3) and if the scale is not moving, i.e. the „LED ~“ is not lit up.

### Manual setting to zero

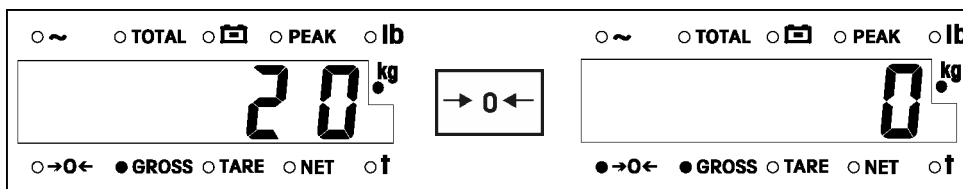

- ⇒ Press button **→0←** in gross mode.  
0 (kg) shall appear in the display and "LED **→0←**" shall illuminate.

### Auto zero with power up

With this function activated in the Service menu (not accessible on verified scales) (see chapter 8.3), the scale is automatically set to zero after powering up.

## 6.5 Taring

Taring is only possible if the scale is not in motion, i.e. the motion „LED ~“ is not lit. Once the tare weight is accepted the scale is working in the net mode.

### Manual taring

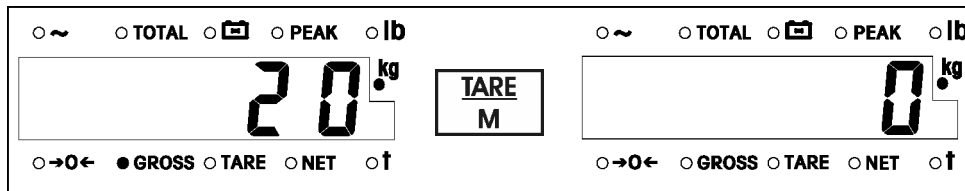

⇒ In gross mode press the **Tare** key. The scale stores the weight value as tare value. The display shows 0 (kg) and the Net LED lights.

### Numeric tare

When you know the tare weight of the container, you don't have to weigh and tare the empty container, you can enter the tare weight on the remote control.

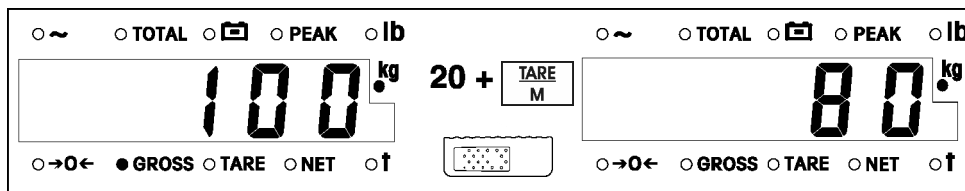

⇒ In gross mode enter the known tare value on the remote control, then press the **Tare** key. The display shows the net weight and the Net LED lights.

## Call up current tare weight

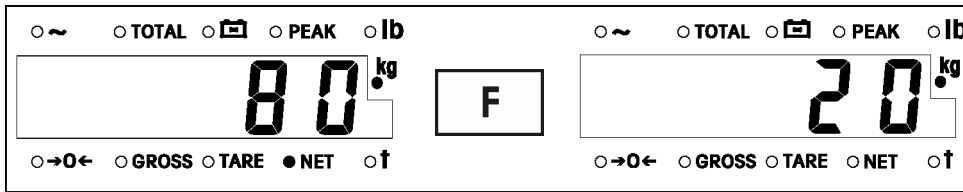

⇒ In net mode press the **F** key.

The tare weight is displayed and the Tare LED lights.

Note:

With the **F** key you can switch between net and tare weight. See chapter 6.7 for working with the accumulation function.

## Clearing tare weight

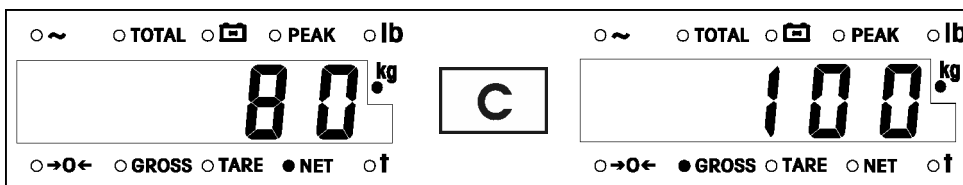

⇒ In net mode press the **C** key.

The tare weight is cleared.

The gross weight is displayed and the Gross LED lights.

## 6.6 Working with the tare weights saved

The crane scale has 10 memories (storage areas 0...9) for tare weights.

The first storage space (0) shall be used for numerical and manual tares. Weights saved here shall be overwritten with manual or numerical tares. For saving tare weights that are used frequently, storage spaces 1 ... 9 should be used.

Note:

Tare weights can only be stored without decimal places.

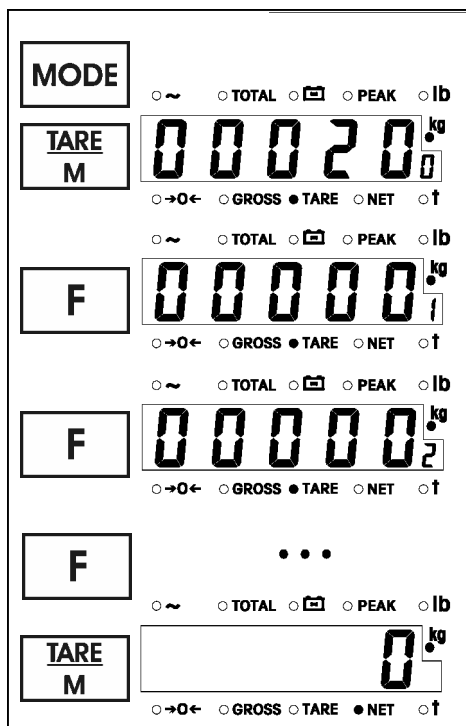

### Calling and taking over the tare weights saved

1. Press mode and tare buttons consecutively.

The content of the first tare memory shall be displayed. The number of the storage area shall be represented by a small figure on the right.

2. Press key F to call the second tare memory.

3. Press key F to call additional tare accumulators.

4. Press the tare button to take over a saved tare weight.

The crane scale changes into net mode and uses the tare weight saved.

### Note

You can transfer into gross mode at any time by pressing button **C**.

### Save new tare weight

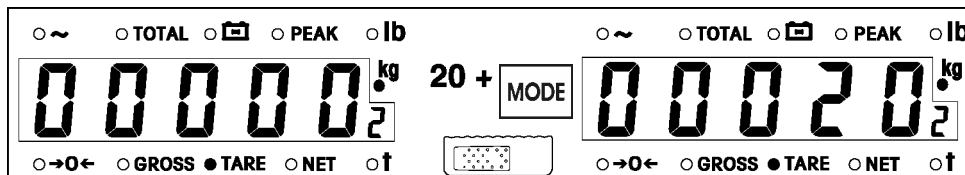

1. Select storage area as described above.
  2. Enter tare weight using the remote control and confirm with the **Mode** key.
- or
- ⇒ Press key →0← and enter the tare weight with the tare and F keys.

### Note

Tare weight entries that have not been confirmed may be cancelled by pressing the →0← key.

## 6.7 Weighing

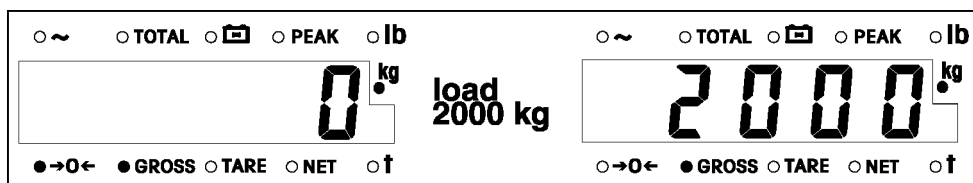

- ⇒ Load the crane scale.  
The weight value is indicated immediately.

### Note

The crane scale offers optical weighing help, i.e. the display blinks if the weight value is not within boundaries set. To do this, an upper and lower limit must be entered in the “Weighing with tolerance range” user menu (see chapter 7.4).

## 6.8 Accumulation

Manual or automatic accumulation must be activated in the User menu (see chapter 7.4).

### Manual accumulating

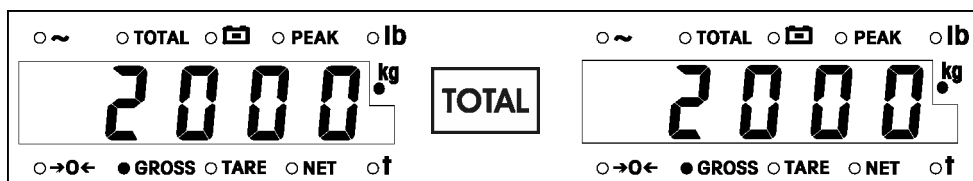

- ⇒ In gross or net mode, press the **Total** key to add the weight value to the accumulator. The Total LED is lit. The internal item counter is increased by 1.

## Automatic accumulating

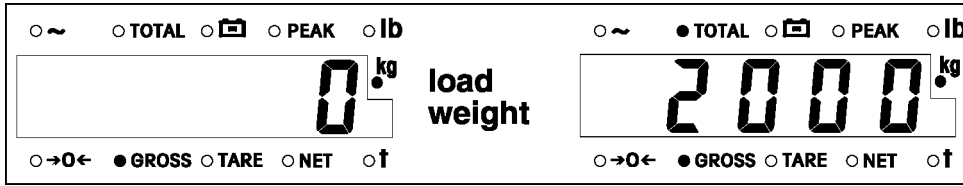

⇒ Load a weight equal or heavier than the minimum accept limit.  
The weight is automatically added to the accumulator. The Total LED is lit. The internal item counter is increased by 1.

### Notes

- The weight is accumulated automatically if it is equal or heavier than the minimum accept limit set in the User menu, see chapter 8.3.
- Between successive weighings the weight value must decrease by 10 digits to be recognized as a new accumulation value.
- When the accumulated weight exceeds 8 digits or the item counter exceeds 4 digits, FULL is displayed and the Total LED is flashing for 5 seconds. The last accumulating is invalid!

### Recall accumulation values

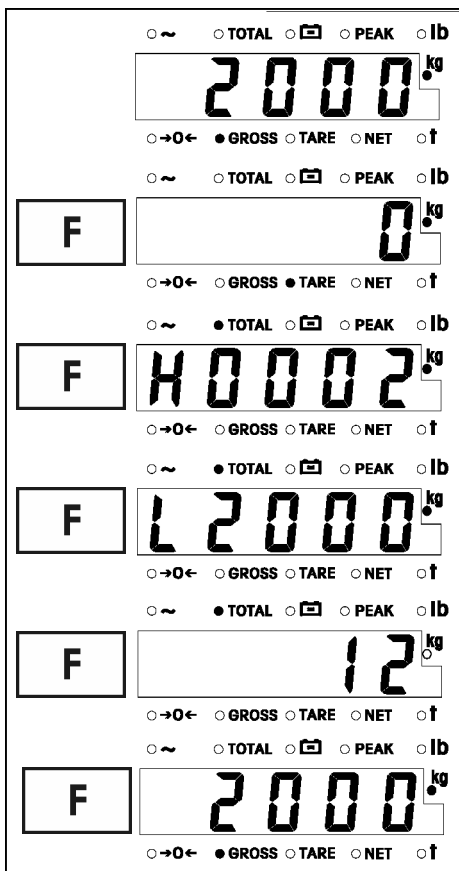

When pressing the **Recall** key repeatedly the crane scale displays the following values:

Tare weight

First 4 digits of the accumulated weight

The last 4 figures of the accumulated weight. In this example the accumulated weight is 22,000kg.

Number of items accumulated

Back to gross mode

## Clearing the accumulator

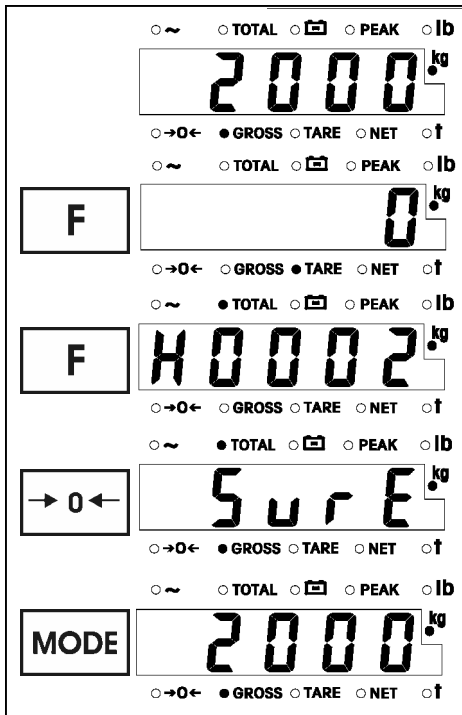

1. Press repeatedly the **F** key to recall the first digits of the accumulated weight (H...)
2. Press key **→0←** in order to delete the amount accumulator..
3. Confirm SAVE with the mode key. The accumulator is cleared; the crane scale is back to gross mode.

## 6.9 Displaying peak weight

To do this, the weighing mode must be set as Hold Mode, see User menu chapter 7.4. In this situation the totalising function is not available.

In Hold mode the crane scale can display the maximum weighed load and then hold this in the display.

### Activating peak weight mode

To start a peak weight measuring cycle in gross or net mode, press the **MODE** and **TOTAL** in succession.

The **PEAK** LED lights up.

While the **PEAK** LED is lit, the scale stores the highest load value of a weighing (peak value).

### Recalling the peak weight

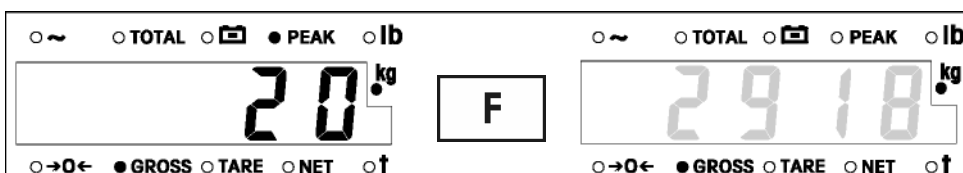

⇒ Press the **F** key, the heaviest load of the last weighing will flash in the display.

### Returning to weighing mode

⇒ Press the **F** key again.

## Returning to the peak weight measuring cycle

⇒ When the peak weight is displayed, press the **C** key. The display changes to the current gross weight and the peak weight measuring cycle is ended.

## Clearing the peak weight

1. When the peak weight is displayed, press the **→0←** keys. The display returns to the actual gross weight.
2. Press the **C** key. The stored peak value is deleted and a new measuring cycle can be started.

## 6.10 Weighing with a tolerance range

To ensure that your weighing value is within a defined tolerance range, you can program separate upper and lower limits. Optical weighing help can support you when using tolerance weighing. If optical weighing help is active, then the weight display will flash when the weight is below the lower limit or above the upper limit.

Weighing with a tolerance range must be activated in the User menu, see chapter 7.4.

### Defining limits

When "Weighing with a tolerance range" is selected as the weighing mode, then the parameters F3.6.1 to F3.6.3 will be available in the user menu, see chapter 7.4.

1. Entering the upper limit, F3.6.1.
2. Entering the lower limit, F3.6.2
3. Activate/deactivate optical weighing help F3.6.3.

## 6.11 Stop weight value (freeze)

Once a stable weight value is detected, you can "freeze" or lock the weight value displayed until it is cleared for the next weighing.

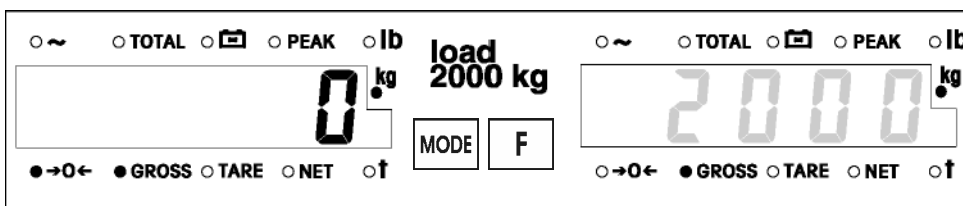

⇒ Press the buttons **Mode** and **F** to "freeze" or hold the current weight value. It will be displayed as long as it isn't cleared.

⇒ To clear the "frozen" or locked weight, press the **C** key.

## 6.12 Battery operation

For optimum battery operation please observe the following:

- ⇒ Do not recharge the battery until it has been fully discharged.
- ⇒ Charge the battery at least every 3 months to keep it in good condition.
- ⇒ When the crane scale is not in use for a long time, remove the battery.

### Battery indicator

There are two levels of battery indicators:

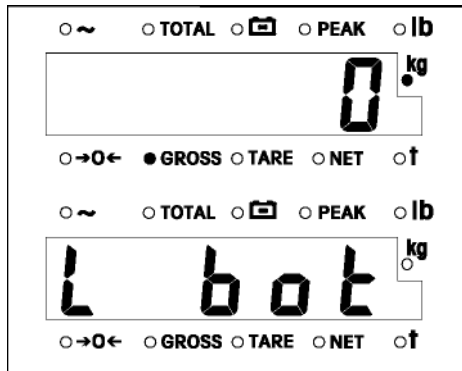

⇒ With the **BAT LOW** LED lit, charge the battery **soon**.

⇒ With the **L bat** display, charge the battery **immediately**

### Notes

- The battery is not warranted due to its service time is greatly influenced by individual use.
- Battery charge is less than normal if the battery is not used for a long time, e.g. for more than 2 months. To return the battery to normal operation conditions cycle the battery at least 3 times by charging it and using it until it is fully discharged.
- Battery charge and scale operation duration will decline with use. We recommend replacement of the battery after 300 charging cycles.

### Checking battery capacity

In the self test the crane scale checks the display and the battery capacity.

⇒ In gross mode press the **C** key. The following is displayed:

- 000000
- 111111
- ...
- 999999
  - bat x, with x = 1 (low) ... 4 (high)

### 6.13 Operation with remote control

The remote control can be operated at distances up to 15 meters.

You can operate all functions except switching on via the remote control. With the remote control the additional function **numeric tare** is possible.

⇒ Aim the top of the remote control to the front of the crane scale. **Notes**

- The red LED must light up with every key touch. If it fails to light up, the batteries of the remote control must be changed, see chapter 10.3.
- Change the batteries every 2 months.

## 7. User menu

In the master mode you can modify parameters concerning your specific weighing application.

### 7.1 Overview

The crane scale menu consists of two areas: The user menu and the service menu for service technicians, see chapter 8. Operation is the same in both areas. The user menu parameters are represented by numbers in the display.

Parameter		Factory settings	
No.	Name	Value	Meaning
F2.4.1	Minimum weight for totalising	0	Totalising is not possible
F2.4.2	Totalising mode	0	off
F2.5	Weighing mode	0	normal
F3.1	Sleep mode	1	On
F3.2	Display luminosity	0	very light
F3.6.1	Upper boundary value		
F3.6.2	Lower boundary value		
F3.6.3	Weighing help	0	Off
F3.7	Save status	0	Off
F3.8	Remote control function	1	On
F4.3	Display test	0	Skip display test
F4.4	Keyboard test	0	Skip keyboard test
F5.1	Exit menu	1	Save changed settings

If no factory settings have been given, then they depend on the model or on the country and its respective laws on measures and calibration.

### 7.2 Accessing the user menu

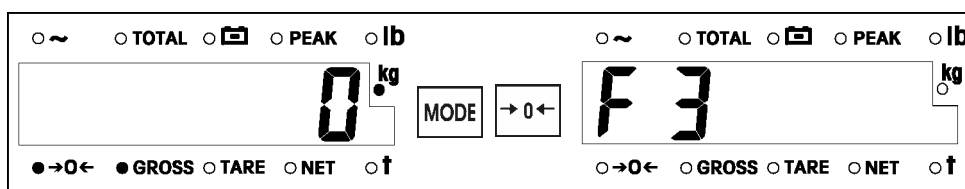

- ⇒ Press the buttons **Mode** and **→0←** simultaneously.  
The final parameter F3 group of the user menu shall be displayed. No LED is lit. The scale is ready for modifying parameters.

### 7.3 Operation in menu

#### Display in user menu

The display is divided in 3 groups:

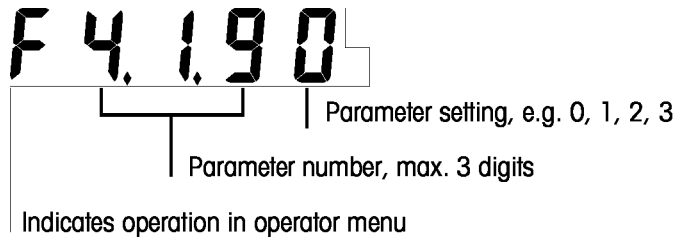

#### Selecting parameter groups or settings

**Example 1:** to get from parameter group F3 directly to parameter group F4

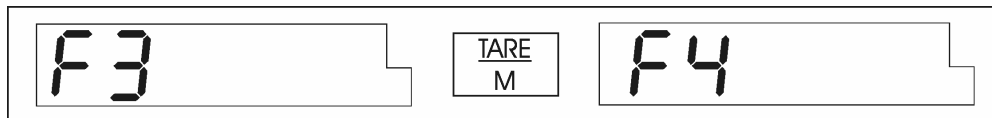

⇒ Press the **Tare** key to get to the next parameter group.

**Example 2:** In order to access sub-parameter F3.1 from parameter group F3

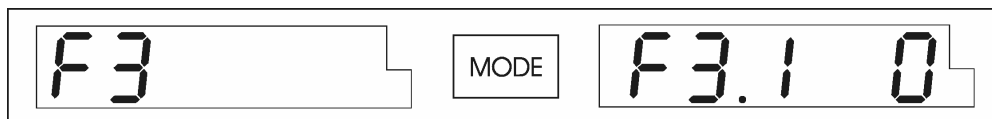

⇒ Press the **Mode** button to access the sub-parameters.

**Example 3:** change setting for parameter F3.1 from 0 to 1

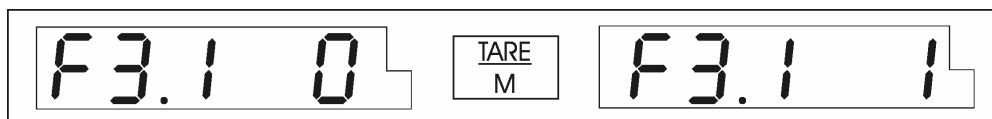

⇒ Press the **Tare** key to change the parameter setting.

## Returning to the previous step

**Example 1:** to return from parameter group F4 to parameter group F3

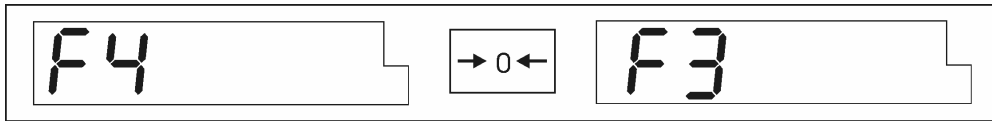

⇒ Press key →0← to access the previous parameter group.

**Example 2:** to return from parameter group F3.8 to parameter group F3.7

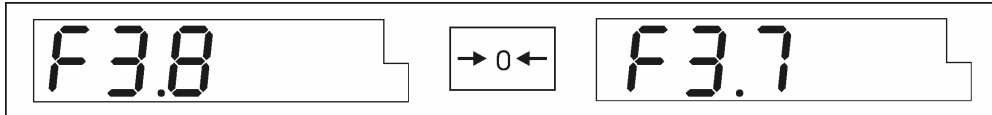

⇒ Press key →0← to access the previous parameter group.

## Confirming selected parameter (settings)



⇒ Press **Mode** button.

The selected parameter (setting) is confirmed and the next master mode step is displayed in the user menu.

## Enter numerical values

The most comfortable way to enter numerical values is via the remote control.  
On the crane scale keyboard use the **Tare** and **F** keys.



⇒ Use the **F** key to increase the flashing digit (in the example: 0) by 1.

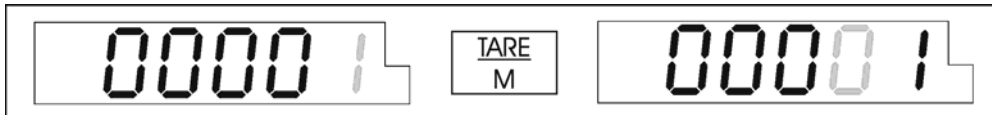

⇒ Use the **Tare** key to move the flashing digit (in the example: 1) one digit to the left.  
The leftmost digit will move to the rightmost digit.

⇒ Use the **Mode** key to confirm the entry and proceed to the next step.

## End menu

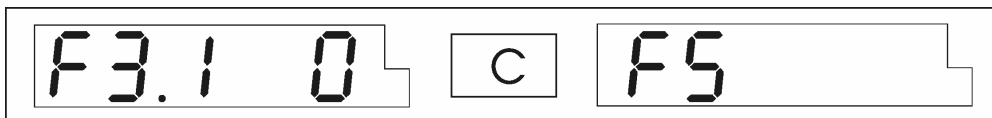

⇒ Press button **C**.

F5, the final parameter group of the user menu shall be displayed.

For further steps see chapter 7.4 or chapter 8.3.

## 7.4 Description of the user menu

Factory settings are printed in **bold**.

### F2.4.1 – Minimum weight for totalising

The current set minimum weight for totalising is displayed immediately.

- ⇒ Use the **MODE** key to confirm the displayed minimum weight
- ⇒ Enter the minimum weight for totalising using the remote control.

or

- ⇒ Press the **→0←** key and use the **Tare** and **F** keys to enter the minimum weight for totalising.

#### Note

For totalising, the minimum weight must be >0.

### F2.4.2 – Totalising

- 0** Totalising **off** (factory setting)
- 1 Manual totalising
- 2 Automatic totalising

#### Note

When using automatic totalising, the weight value between two successive weighings must decrease by at least 10 digits, to be recognised as a new totals value.

### F2.5 – Weighing mode

- 0** **Normal** weighing (factory setting)
- 1 Hold mode
- 2 Weighing with tolerance range

#### Note

- In Hold mode the scale displays the maximum weight up to that point and holds this value in the display. The Total LED lights up. In this mode, totalising is not possible.
- When weighing with a tolerance range is selected, you will see the parameters F3.6.1 to F3.6.3 in the User menu.

### **F3.1 – Sleep mode**

The crane scale will enter sleep mode if the keyboard is not in use and if the weight has not changed for 5 minutes. SLEEP will be displayed. To escape the sleep mode, press a key on the keyboard or on the remote control.

- 0 Sleep mode is switched off
- 1 Sleep mode **activated** (factory setting)

### **F3.2 – Display luminosity**

- 0 **Very light** (factory setting)
- 1 Light
- 2 Dark

### **F3.6.1 – upper boundary value**

This parameter only appears when the “boundary value monitoring” weighing mode is selected in the service menu.

After selecting the parameter, the current upper boundary value set shall appear.

⇒ Enter the upper boundary values with the remote control.

or

⇒ Enter the upper boundary value with the buttons **Tare** and **F**.

### **F3.6.2 – lower boundary value**

This parameter only appears when the “boundary value monitoring” weighing mode is selected in the service menu.

After selecting the parameter, the current lower boundary value set shall appear.

⇒ Enter the lower boundary values with the remote control.

or

⇒ Enter the lower boundary value with the buttons **Tare** and **F**.

#### **Note**

The lower boundary value must be smaller than the upper value.

### **F3.6.3 – initial weight help**

This parameter only appears when the “boundary value monitoring” weighing mode is selected in the service menu.

- 0 **No** optical initial weight help (factory setting)
- 1 The weight display flashes when weight falls below the lower boundary value or exceeds the upper boundary value.

### F3.7 – Memory retention

When memory retention is enabled, the crane scale returns to the last status (zero point, gross/net mode etc.) when powering up.

**0** Save status **off** (factory setting)

1 Save status on

### F3.8 – Remote control function

0 Remote control function disabled

1 Remote control function **enabled** (factory setting)

### F4.3 – display test

⇒ Press the **Mode** key in order to skip the keyboard test and continue with step F4.4.  
or

⇒ Press the **Tare** key to enter the keyboard test (F4.3 1), then press the **Mode** key to start the keyboard test.

The following is displayed:

- All possible numbers: from only zeros through only nines,
- all LEDs illuminate

When F4.4 is displayed, the display test is finished.

### F4.4 – keyboard test

⇒ Press the **Mode** key in order to skip the keyboard test and continue with step F5.1.  
or

1. Press the **Tare** button to select keyboard test (F4.41) then press the **Mode** button again in order to start the keyboard test.  
E is displayed.

2. Press the **Mode** button and then press all of the keys on the keyboard from right to left. The number in the display indicates the key number (from the right) to be pressed next.

Pressing the →**0**←-button ends the keyboard test and the next parameter (F5) appears.

### F5.1 – End menu

1 Saves settings

2 Restores the most recently saved parameters

## 8. Service menu

### 8.1 Overview

Parameter		Factory settings	
No.	Name	Value	Meaning
F1.2	Digital filter	2	medium
F1.5	Taring	1	On
F1.6.2	Automatic zero points	0	Off
F1.6.3	Reset area when switching on	2	+/-10 %
F1.6.4	Reset area for manual reset	1	+/-2 %
F1.7.1	Area for motion sensor	1	+/-0.5 d
F1.8	Edit weighing unit		
F1.9	Select capacity		
F1.10	Select resolution		
F1.11	Calibrate mode	0	Standard
F1.12	Calibration	0	Skip calibration
F1.13	Zero adjustment	0	Skip zero adjustment
F1.14	Span adjustment	0	Skip span adjustment
F2.6	Switching weight unit	0	Off
F2.7	Geo-value		
F4.1	Expanded display	0	Off
F5.1	Exit menu	1	Save changed settings

If no factory settings have been given, then they depend on the model or on the country and its respective laws on measures and calibration.

## 8.2 Access service menu

Parameters which can be changed in Service Mode are protected through verification. On a verified crane scale, the verification seal must first be destroyed in order to activate Service Mode. It is then necessary to re-verify the crane scale.

Entering the service menu, small construction

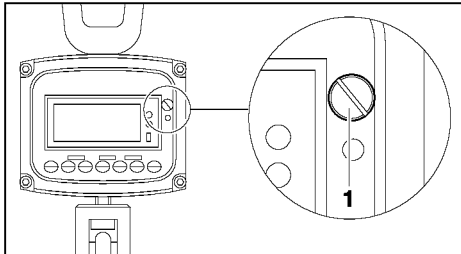

1. Remove the sealing screw (1) \*.
  2. Switch on the scale.
  3. Press the switch in the hole. The display shows F1.
- The scale is ready for modifying parameters.

Entering the service menu, large construction

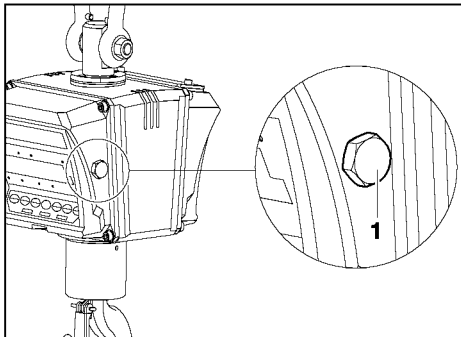

1. Remove the sealing screw (1) \*.
  2. Switch on the scale.
  3. Press the switch in the hole. The display shows F1.
- The scale is ready for modifying parameters.

### Operation in service menu

Navigation in the service menu is the same as in the user menu, see chapter 7.3.

\* To do this on verified scales the lead seal must be destroyed; the verification status is then no longer valid, see chapter 8.4.

### 8.3 Description of service menu

Factory settings are printed in **bold**.

#### F1.2 – Digital filter

The digital filter stabilises the weight display when

- 0 Filter off
- 1 Filter setting low
- 2** Filter setting **medium** (factory setting)
- 3 Filter setting high

#### F1.5 – Tare operation

Tare operation can be enabled or disabled.

- 0 Tare function off
- 1** Tare function **on** (factory installation)

#### F1.6.2 – Auto zero operation

Zero setting within a set threshold value can be done automatically by the crane scale.

- 0** Automatic reset **off** (factory setting)
- 1 Automatic reset in +/-0.5 d area
- 2 Automatic reset in +/-1.0 d area
- 3 Automatic reset in +/-3 d area

#### F1.6.3 – Auto zero with power up

When the crane scale is powered up it will re-zero based on the tolerances below.

- 0** Automatic reset **off** when switching on (factory setting)
- 1 Automatic reset when switching on in +/-2% area
- 2 Automatic reset when switching on in +/-10 % area
- 3 Automatic reset when switching on in +/-100 % area

#### F1.6.4 – Manual zero operation

This setting affects the tolerance of the pushbutton or remote control zero.

- 0 Manual reset off
- 1 Manual zero operation with **zero range  $\pm 2\%$**  (factory setting)
- 2 Manual reset in reset area  $\pm 20\%$
- 3 Manual reset in reset area  $\pm 100\%$

#### F1.7.1 – Motion detection

With the motion detection you can determine the stability of the weight value. It affects the acceptance of a zero or tare request when the load is vibrating or moving.

- 0 Motion sensor switched off
- 1 **Motion detection range  $\pm 0.5 d$**  (factory setting)
- 2 Motion sensor in  $\pm 1 d$  area
- 3 Motion sensor in  $\pm 3 d$  area

#### F1.8 – Weight unit

The possible weight units depend on the capacity of your crane scale and on verification.

- 0 Edit weighing unit **kg**
- 1 Edit weighing unit lb 1 lb  $\approx$  0.454 kg
- 2 Weight unit: t (metric tonne), 1 mt = 1000 kg  
large construction only

#### F1.9 – Capacity selection

After 2 seconds the current capacity is displayed.

⇒ Press key →**0**← and enter the tare weight with the **tare** and **F** keys.  
or

⇒ Press the **Mode** key to confirm the displayed capacity.

#### Note

You can set a capacity equal to or less than the maximum capacity specified for your crane scale.

### F1.10 – Select resolution

After 2 seconds the current set resolution will be displayed.

- ⇒ Press the **Mode** key, to confirm the displayed capacity
- ⇒ Press the **Tare** key, to set the resolution in accordance with the following table.

<b>Capacity</b>	<b>Resolution</b>			<b>Capacity resolution</b>			
<b>150</b>	0.02	0.05	0.1	<b>3000</b>	0.5	1	2
<b>300</b>	0.05	0.1	0.2	<b>6000</b>	1	2	5
<b>600</b>	0.1	0.2	0.5	<b>10000</b>	2	5	10
<b>1500</b>	0.2	0.5	1				

### F1.11 – Adjustment mode

The crane scale offers two adjustment procedures: Standard and 3 point adjustment, see F.1.12.

#### 0 Standard adjustment (factory setting)

- 1 3 point adjustment

### F1.12 0 – Adjustment

#### 0 Skip adjustment (factory setting)

- 1 Activate adjustment

#### Notes

- Do not enter adjustment unless you have sufficient test weights, min. 20 % of the capacity.
  - For highest accuracy use test weights of 80 % or more.
  - Test weights should relate to the lowest significant digit, e.g. with a lowest significant digit of 5 kg the test weight should be a multiple of 5 kg.
- ⇒ Press the **Mode** key in order to skip the adjustment and continue with step F1.13.

or

- ⇒ Press the **Tare** key to enter adjustment (F1.12 1), then press the **Mode** key to start the adjustment procedure according to the setting in F1.11.

## Standard setting

Display	Key	Description
E SCL *		Unload the scale
	<b>Mode</b>	The scale shall wait for a stable weight value
15 SCL ... 0 SCL		While counting down from 15 to 0 the scale records zero
Add L *		Attach test weight of at least 20% of capacity
	<b>Mode</b>	Confirm attachment of test weight
000000		Enter weight value for test weight
	<b>Tare, F or remote control</b>	Enter weight value
002000		Enter weight value for test weight
	<b>Mode</b>	Confirm weight value
15 SCL ... 0 SCL		While counting down from 15 to 0 the scale records span
CAL d		Adjustment complete. This message is displayed for 2 seconds.
F1.130		Next step in service menu

\*When these displays appear, adjustment may be cancelled by pressing the →0← button.

### 3 point adjustment

Display	Key	Description
E SCL *		Unload the scale
	<b>Mode</b>	The scale shall wait for a stable weight value
15 SCL ... 0 SCL		While counting down from 15 to 0 the scale records zero
Add H *		Attach test weight of at least 50 % of capacity
	<b>Mode</b>	Confirm attachment of test weight
000000		Enter weight value for test weight
	<b>Tare, F</b> or remote control	Enter weight value
002000		Enter weight value for test weight
	<b>Mode</b>	Confirm weight value
15 SCL ... 0 SCL		While counting down from 15 to 0 the scale records high span
Add L*		Attach test weight of at least 10 % of capacity
	<b>Mode</b>	Confirm attachment of test weight
000000		Enter weight value for test weight
	<b>Tare, F</b> or remote control	Enter weight value
002000		Enter weight value for test weight
	<b>Mode</b>	Confirm weight value
15 SCL ... 0 SCL		While counting down from 15 to 0 the scale records low span
CAL d		Adjustment complete. This message is displayed for 2 seconds
F1.130		Next step in service menu

\*When these displays appear, adjustment may be cancelled by pressing the →0← button.

### **F1.13 0 - Zero adjustment**

This function allows re-zeroing after removing chains, slings and lifting devices used in calibration.

#### **0 Skip zero setting** (factory setting)

##### 1 Activate zero setting

⇒ Press the Tare key to enter zero adjustment.

⇒ Remove all weight from the scale and then press the Mode key.

⇒ The scale counts down from 15 SCL to 0 SCL while recording zero.

⇒ When F14.1 0 is displayed, zero adjustment is finished.

### **F1.14 0 – Not documented**

Changes can not be made.

### **F2.6 – changing weight units**

#### **0 No switching** (factory setting)

##### 1 Switching from lb to kg

##### 2 Switching from kg to lb

### **F2.7 – geo value**

For adjustment to local gravitational relationships.

The current geo values set are displayed.

1. The appropriate geo values of the tables can be found in chapter 11.
2. Press the →0← key and use the **Tare** and **F** keys to enter the appropriate Geo value.

or

⇒ Press the **Mode** button in order to confirm the geo value displayed.

### **F4.1 – Expanded display**

In expanded display operation the weight value is indicated with the internal interval.

##### 1 (normal) resolution point = 10 internal resolution points

#### **0 Enlarged display off** (factory setting)

##### 1 Enlarged display activated

## **F5.1 – End service menu**

- 1 Save settings**
- 2 Restores the most recently saved parameters
- 3 Resets the factory settings **information**

When “restore factory settings” has been selected, "SURE" shall appear in the display. Confirm this enquiry with the **Mode** key.

## **8.4 Verification**

### General:

According to the EU guideline 90/384/EEC balances must be verified officially if they are to be used as follows (legally regulated area):

- a) For commercial transactions if the price of goods is determined by weighing
- b) For the production of medicines in pharmacies as well as for analyses in the medical and pharmaceutical laboratory
- c) For official purposes
- d) For the production of finished packages

In case of doubt, please contact your local office of weights and measures.

### Verification information

An EU qualification approval is available for those balances marked as appropriate for verification in the technical data. In the event that the balance is applied in an area subject to verification as described above, it must be officially verified and re-verified at regular intervals.

Re-verification of a balance is carried out in compliance with the respective legal provisions of the states. The term of verification validity for balances in Germany, for example, is normally 2 years.

The legal provisions of the country of use are to be observed.

After verification the seal screw is plumbed with a seal thread.

**Verification of the balance is invalid without the seal.**

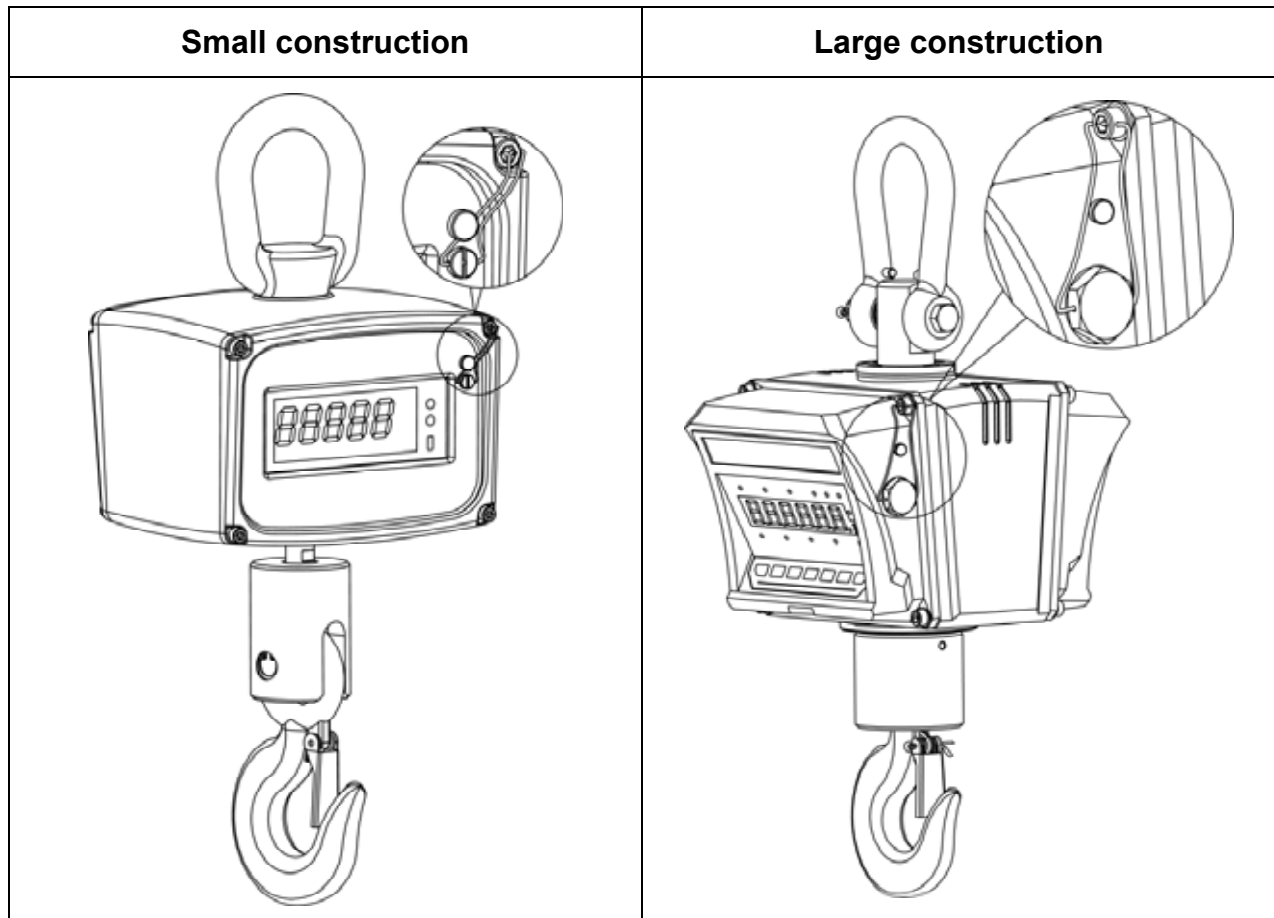

Position of the seal:



**Balances with obligatory verification must be taken out of service if:**

- **The weighing result of the balance is outside the maximum limits of operating errors.** Therefore load balance is regular intervals with known test weight (ca. 1/3 of the max. load) and compare with displayed value.
- **The date for subsequent or periodical verification has passed.**

## 9. Error messages

Error code	Fault	Remedy
E1, E2, E3	Internal error	⇒ Switch crane scale off and then on again ⇒ If message is still on, call Service
E35	Adjustment weight to low	⇒ Attach additional test weight
E37	Scale in motion	⇒ Re-adjust
Full	Overflow data accumulator	⇒ Data record deletion
	Underload, i.e. weight below power on auto zero limit	⇒ Unload the scale ⇒ Press button →0← ⇒ If message is still on, call Service
	Overload, i.e. weight is 9 digits over full capacity	⇒ Decrease the load ⇒ Check if the scale has not been damaged
Weight values are drifting	Internal error	⇒ Inform service
BAT LOW	Low battery voltage	⇒ Recharge the battery
L bAT	Battery power low, automatic switch off in one minute	⇒ Charge the battery immediately
SLEEP	Sleep mode, automatically entered when the weight has not changed and the scale was not in use for 5 minutes	⇒ Press any key on the keyboard of the scale or on the remote control
Remote control does not work	<ul style="list-style-type: none"> <li>• IR windows dirty</li> <li>• Low battery voltage</li> </ul>	⇒ Clean the window on top of the remote control and the receiving window on the crane scale with alcohol and a clean cloth  ⇒ Change the batteries of the remote control

## 10. Maintenance & Cleaning

 <p><b>Danger</b></p>	<p><b>Risk of injury and damage! The crane scale is part of the lifting gear!</b> <b>For safe operation observe the following:</b></p> <ul style="list-style-type: none"><li>⇒ Have regular inspections be done by trained experts,</li><li>⇒ Carry out regular servicing and maintenance, see chapters 10.1 and 10.2</li><li>⇒ Have parts replaced only by trained experts.</li><li>⇒ If there are discrepancies with the safety checklist, then the scale should not be used.</li><li>⇒ Do not repair the crane scale yourself. Repairs must only be carried out by service partners authorised by KERN.</li></ul>
--	--

### 10.1 Regular maintenance

- ▲ The regular 3-month service must only be carried out by experts with thorough knowledge of working with crane scales. When doing this, national accident prevention regulations, as well as the operator's work, operating and safety regulations are to be taken into account.
- ▲ The regular 12-month service must only be carried out by trained experts (KERN service).
- ▲ The results of this service are to be entered into the checklist (chapter 10.2).
- ▲ The additional results of the extended service are to be entered into the checklist (chapter 11.1).
- ▲ Replaced parts are also to be entered, (chapter 11.2)

**Regular service:**

<p>Every <b>3 months</b> or in any case after <b>12,500 weighings</b></p>	<ul style="list-style-type: none"> <li>▪ Check all dimensions, see checklist chapter 10.2</li> <li>▪ Check shackle or loop for wear, such as for example, plastic deformation, mechanical damage (unevenness), notches, grooves, cracks, corrosion, damage to thread and distortions.</li> <li>▪ Check the fit of the safety latch on the hook, also check it for defects and make sure that it operates correctly</li> <li>▪ When weighing using the large construction: check that the splint and nut on the shackle are not loose</li> </ul> <p>If a dimension should be below the permissible deviation from the original dimension (see checklist, chapter 10.2) or if there are other discrepancies, the scale must be repaired immediately by trained experts (KERN Service). Do not repair it yourself under any circumstances. Take the scale out of operation immediately!</p> <p>All repairs and replacement parts must be documented by the service partner (see list, chapter 11.2).</p>
<p>Every <b>12 months</b> or in any case after <b>50,000 weighings</b></p>	<ul style="list-style-type: none"> <li>▪ The extended service must be carried out by trained experts (KERN Service). In this general inspection, all load-carrying parts must be checked for cracks using magnetic powder</li> </ul>
<p>Every <b>5 years</b> or in any case after <b>250,000 weighings</b></p>	<ul style="list-style-type: none"> <li>▪ All load-carrying parts must be replaced by trained experts (KERN Service).</li> </ul>
<p>Every <b>10 years</b> or in any case after <b>500,000 weighings</b></p>	<ul style="list-style-type: none"> <li>▪ Replace the crane scale completely</li> </ul>

**Note**

When checking for wear, pay attention to the following descriptions (chapter 10.2).

## 10.2 Checklist for regular safety inspections

Original measurements for crane scale with serial number .....										Capacity .....	
Shackle or hanging ring					Hook					Wear	Safety latch
a (mm)	b (mm)	c (mm)	Wear	Split pin & nut	d (mm)	e (mm)	f (mm)	g (mm)	Angle $\alpha$ (°)	Wear	Safety latch

Date ..... Inspector .....

Max. allowed deviation	Shackle or hanging ring				Hook				Date	Inspector				
	a	b	c	Wear (check grey areas)	d	e	f	g			Angle $\alpha$	Wear (check grey areas)	Safety latch	
Initial check before first use														
3 months / 12'500 x														
6 months / 25'000 x														
9 months / 37'500 x														
<b>12 months / 50'000 x</b>														
15 months / 62'500 x														
18 months / 75'000 x														
21 months / 87'500 x														

	Shackle or hanging ring				Hook				Date	Inspector		
	a	b	c	Wear (check grey areas) No distortion or cracks	Split pin & nut Sitting tight	d	e	f			g	Angle $\alpha$
Max. allowed deviation	5 %	0 %	5 %	No distortion or cracks	Sitting tight	10 %	5 %	5 %	5 %	10°	No distortion or cracks	Working properly
<b>24 months / 100'000 x</b>												
27 months / 112'500 x												
30 months / 125'000 x												
33 months / 137'500 x												
<b>36 months / 150'000 x</b>												
39 months / 162'500 x												
42 months / 175'000 x												
45 months / 187'500 x												
<b>48 months / 200'000 x</b>												
51 months / 212'500 x												
54 months / 225'000 x												
57 months / 237'500 x												
<b>60 months / 250'000 x</b>												
<input type="checkbox"/> Have METTLER TOLEDO service replace all load bearing parts.												

**Bold print** means that an extended safety check has to be performed by service partners authorised by KERN

**Small construction:**

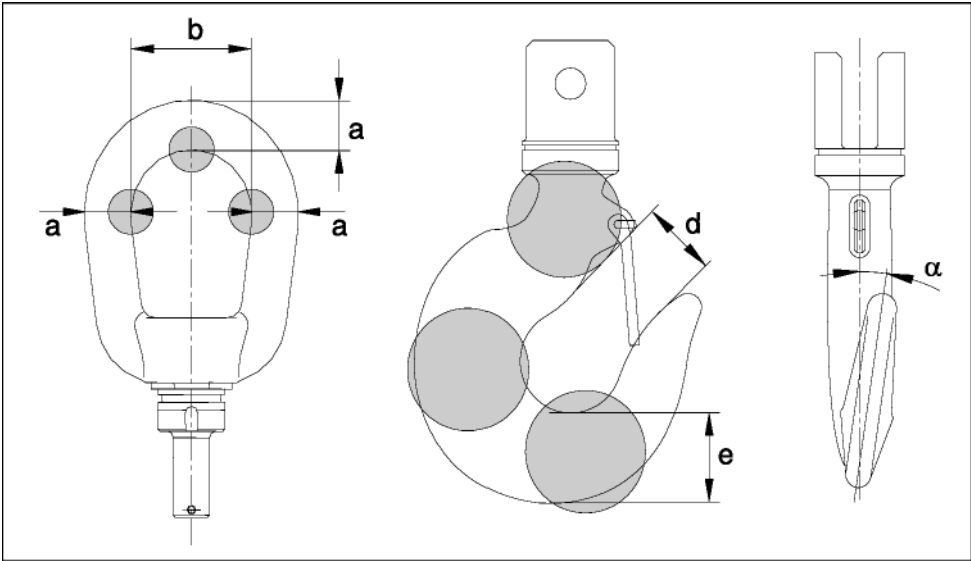

**HTS 150 kg – 600 kg**

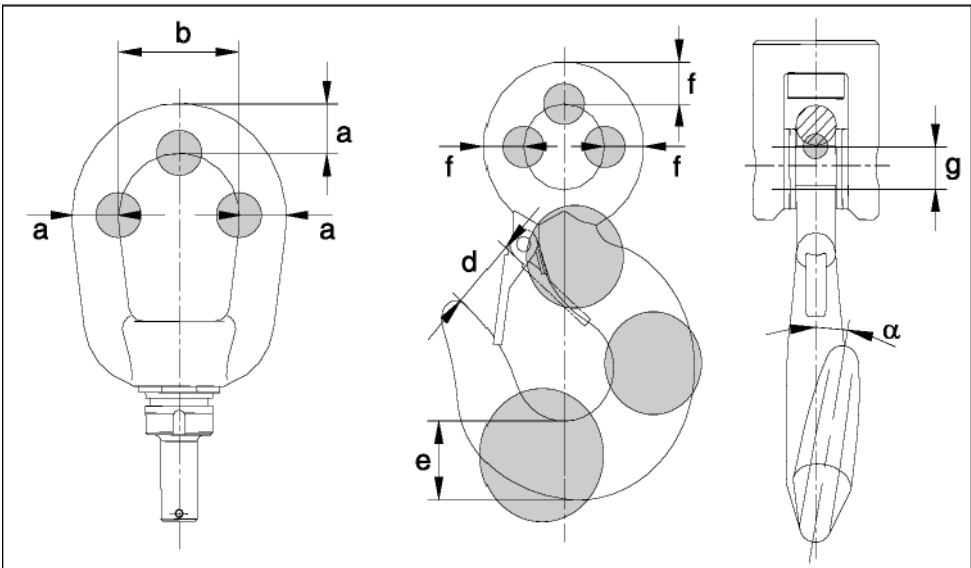

**HTS 1.5 t**

## Large construction:

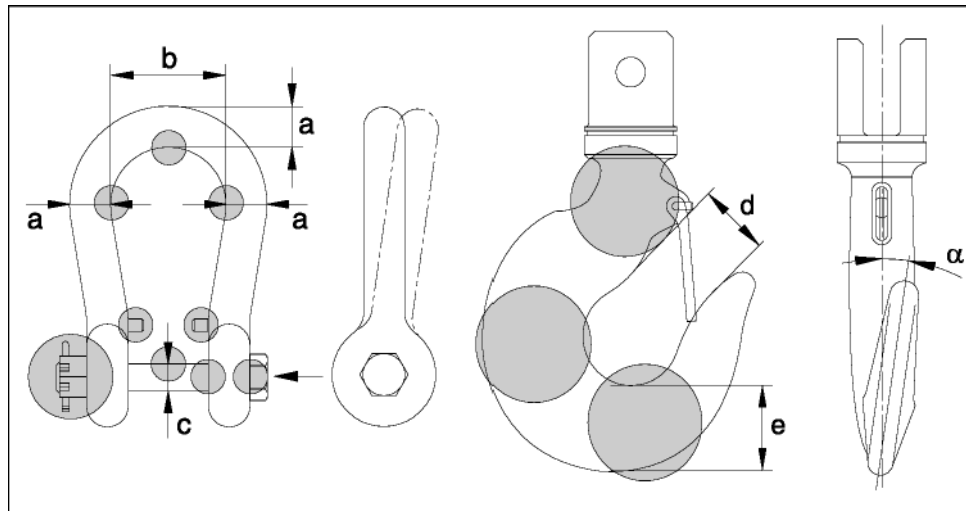

## 10.3 Cleaning

 <p><b>CAUTION</b></p>	<p><b>Damage to the crane scale!</b></p> <p>⇒ Do not use any type of industrial solvents or chemicals.</p>
--	--

⇒ Clean the keyboard and the display with a soft cloth that has been dampened with a mild window type cleaner or detergent.

## 10.4 Changing the batteries of the remote control

To change the batteries, the remote control has to be taken from the yellow rubber housing.

1. Push the head of the remote control slowly out of the rubber housing through the upper hole on the back of the housing and pull the black remote control out.
2. Undo the battery compartment cover and replace the batteries. Be sure that the battery poles are positioned correctly.
3. Close the battery compartment and slip the remote control into the yellow housing.

# 11. Enclosure

## 11.1 Checklist extended safety inspection

The extended safety inspection may only be performed by service partners authorised by KERN

Crane scale		Model .....	Serial number.....				
Interval	Magnetic particle crack detection	Hook	Shackle	BOA-CM screw connections	Date	Name	Signature
12 months / 50'000 x							
24 months / 100'000 x							
36 months / 150'000 x							
48 months / 200'000 x							
60 months / 250'000 x							
72 months / 300'000 x							
84 months / 350'000 x							
96 months / 400'000 x							
108 months / 450'000 x							
120 months / 500'000 x							

Replace the crane scale completely.



