

Inscale Measurement Technology

www.inscale-scales.co.uk

ACB_{plus} SERIES

(P.N. 4278, Rev. B4, january 2005)

Software rev.: 1.13 for standard models
1.9 for ACB_{plus}-1000 and
2.1H for ACB_{plus}-600H

CONTENTS

1.0	INTRODUCTION	2
2.0	SPECIFICATIONS	3
2.1	TECHNICAL SPECIFICATIONS	3
2.2	COMMON SPECIFICATIONS	3
3.0	INSTALLATION	4
3.1	LOCATING THE SCALE.....	4
3.2	SETTING UP THE SCALE.....	4
3.3	BATTERY CHARGING.....	5
3.4	DISPLAY	5
3.5	KEY DESCRIPTIONS.....	6
4.0	OPERATION.....	7
4.1	ZEROING THE DISPLAY	7
4.2	TARING.....	7
4.3	WEIGHING.....	8
4.4	PERCENT WEIGHING	8
4.5	PARTS COUNTING.....	9
4.6	ACCUMULATION.....	9
5.0	PARAMETERS	10
5.1	SELECTING THE UNITS.....	11
5.2	SETTING OF THE BACKLIGHT	12
5.3	SETTING THE PRINTING PARAMETERS.....	13
5.3.1	Selecting the communication port.....	13
5.3.2	Setting the print mode.....	13
5.3.3	Setting the baud rate.....	13
5.3.4	Parity settings	14
5.4	SETTING OF AUTO-SWITCH-OFF.....	14
5.5	TECHNICAL PARAMETERS.....	14
6.0	CALIBRATION.....	15
7.0	COMMUNICATION WITH A COMPUTER/PRINTER	15
8.0	ERROR MESSAGES	16

1.0 INTRODUCTION

- The ACB_{plus} series of scales are simple and easy to use.
- The scales can be operated with an A.C. adapter or using an internal rechargeable battery.
- The weighing process is fast and accurate, making it suitable for the general purpose weighing applications, parts counting, percentage weighing functions, etc.
- There are 7 models in this series with capacities ranging from 150 grams to 3 kilograms.
- All models include automatic zero tracking, automatic tare, accumulation facility that allows the weight to be stored and recalled as an accumulated total and bi-directional RS-232 interface for communicating with a PC or printer.
- All have stainless steel weighing platforms on an ABS plastic base assembly.
- Keypads are sealed with colour coded membrane switches.
- The scales have an optional weigh below facility.
- The displays are large, easy to read liquid crystal type displays (LCD). It is provided with a backlight and also a bar-graph at the bottom to display the weight of the item on the pan with respect to the capacity of the scale.
- The LCD normally shows the weight and the units of the weight selected previously (Grams, Carats, Pounds, etc). See section 5.1 for details on Units.

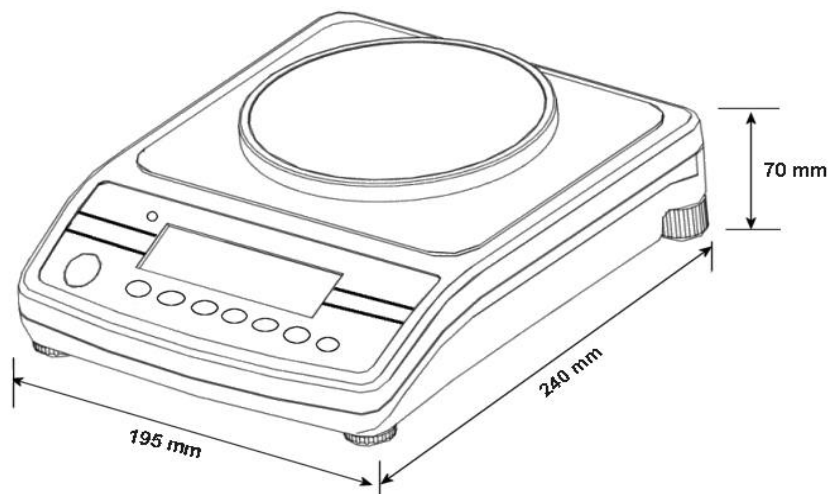

2.0 SPECIFICATIONS

2.1 TECHNICAL SPECIFICATIONS

	ACB plus -150	ACB plus -300	ACB plus -600	ACB plus -600H	ACB plus -1000	ACB plus -1500	ACB plus- 3000	
Maximum Capacity	150g	300g	600g	600g	1000g	1500g	3000g	
Readability	0.005g	0.01g	0.02g	0.01g	0.01 g	0.05g	0.1g	
Tare Range	150g	300g	600g	600g	1000 g	1500g	3000g	
Repeatability (s.d.)	0.005g	0.01g	0.02g	0.01g	0.01 g	0.05g	0.1g	
Linearity ±	0.01g	0.02g	0.04g	0.02g	0.02 g	0.1g	0.2g	
Pan	Φ120mm (4.7")						124x144mm (4.9"X5.7")	
Wind shield	Included as standard							
Units of Measure	g / ct / Lb / OZ / d / GN / OZt / dWt / MM / TL.T / TL.C / TL.t / t / N /g2.							

2.2 COMMON SPECIFICATIONS

Interface	RS-232, bi-directional
Stabilisation Time	2 Seconds typical
Operating Temperature	0°C - 40°C / 32°F - 104°F
Power supply (external)	9VDC / 800 mA
Calibration	Automatic External
Display	16mm high 6 digits LCD With auto backlight and loading bar graph
Scale Housing	ABS Plastic with Stainless Steel platform
Overall Dimensions (wxdxh)	195 x 240 x 70mm (7.7" x 9.5" X 2.8")
Net Weight	1.5 kg (3.3 lb.)

3.0 INSTALLATION

3.1 LOCATING THE SCALE

- Avoid extreme temperatures. Do not place the scale in direct sunlight or near air conditioning vents. Avoid air movement such as from fans or opening of doors and windows.
- Avoid unsuitable tables. The table or floor must be rigid and not vibrate. Do not place near vibrating machinery.
- Avoid unstable power sources. Do not use the scale near any large user of electricity such as welding equipment or large motors.
- Avoid high humidity that might cause condensation. Avoid direct contact with water. Do not spray or immerse the scales in water.
- Keep the weighing area clean.
- Do not stack material on the scale when not in use.
- Protect the scale from extreme temperatures, vibration and dust.

3.2 SETTING UP THE SCALE

- Remove the Shipping Protection screw from the bottom of the base.

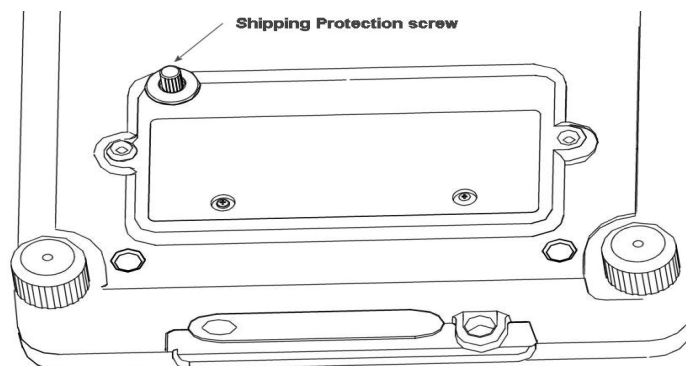

- The scale comes with a stainless steel platform, packed separately.
- Place the platform in the receptacles on the top cover.
- Do not press with excessive force- it could damage the load cell inside.
- Level the scale by adjusting the four feet. The scale should be adjusted such that the bubble in the spirit level is in the centre of the level and the scale is supported by all four feet.
- Turn the power on by pressing the **[On/Off]** switch.
- The unit will display the model number and the software revision number for a while and then will count down performing a self-test.
- When ready the display will show zero along with the weighing unit selected during the last operation.

3.3 BATTERY CHARGING

- The scales can be operated from the internal rechargeable battery or using an A.C. Adapter. The battery life is approximately 24 hours depending on the usage of the backlight.
- The display will show an indication when the battery needs to be charged. To charge the battery, plug in the AC adapter at the back of the scale and attach it to the main power supply. The charging indicator at the left top corner of the LCD will be on.

3.4 DISPLAY

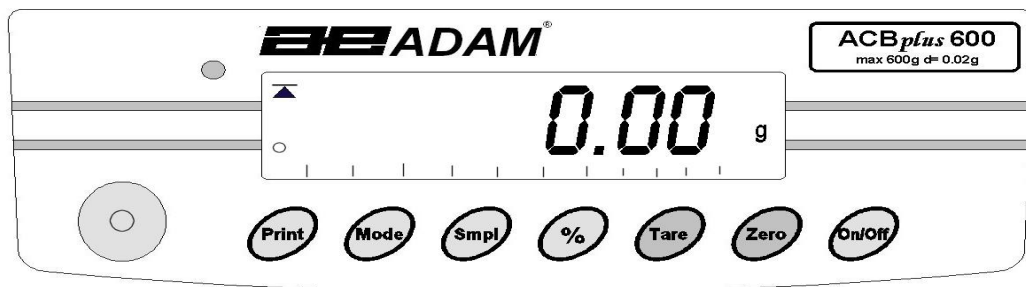

3.5 KEY DESCRIPTIONS

KEYS	PRIMARY FUNCTION	SECONDARY FUNCTION
[On/Off]	To turn the scale On or Off.	----
[Zero]	Sets the zero point for all subsequent weighing. The display shows zero.	A secondary function is of " Enter " key for setting parameters or other functions.
[Tare]	Tares the scale. Stores the current weight in memory as a tare value, subtracts the tare value from the weight and shows the results. This is the net weight.	Pressing [Tare] again will cancel the tare value.
[%]	Enters the percent weighing function.	When in percentage mode, press [%] key to return to normal weighing mode.
[SmpI]	Use this key to enter counting mode from the normal weighing mode,	A secondary function allows the user to return to normal weighing mode while in counting mode. It also clears the accumulated value from the memory when pressed during recalling the total.
[Mode]	Pressing this key will cycle through the weighing units which are enabled. It also scrolls through the options during setting up a parameter.	Displays the unit weight , total weight and the count when in the parts counting mode.
[Print]	To print the results to a PC or printer using RS-232 (A USB interface will be available shortly). It also adds the value to the accumulated memory if the accumulation function is not automatic.	Secondary function is to return to normal operation when the scale is in a parameter setting mode.

4.0 OPERATION

4.1 ZEROING THE DISPLAY

- Press the **[Zero]** key when the platform is empty.
- **[Zero]** key may be pressed at any time to set the zero point from which all other weighing and counting is measured.
- When the zero point is obtained the “**O**” indicator will be on in the left bottom corner of the LCD.
- The scale has an automatic re-zeroing function to account for minor drifting or accumulation of material on the platform. However you may need to press the **[Zero]** key to re-zero the scale if small amounts of weight are shown when the platform is empty.

4.2 TARING

- Zero the scale by pressing the **[Zero]** key, if necessary.
- The “**O**” indicator will be on.
- Place a container on the platform, a value for its weight will be displayed.
- Press the **[Tare]** key to tare the scale. The weight that was displayed is stored as the tare value. It is subtracted from the displayed value, leaving zero on the display. The **NET** symbol will be on at the right top corner to indicate that the weight displayed is the net weight.
- As the product is added, only the net weight will be shown.
- The scale could be tared a second time if another type of product was to be added to the first one. Again only the weight that is added after taring will be displayed.
- When the container is removed a negative value will be shown. If the scale was tared just before removing the container, this value is the gross weight of the container plus all products those were removed.
- The “**O**” indicator will also be on because the platform is back to the same condition as it was when the **[Zero]** key was last pressed.
- To cancel the tare value, press **[Tare]** again.

4.3 WEIGHING

- After zeroing the display and taring the container, place the sample in the container to determine the weight of the sample. The weight will also be displayed through a bar-graph at the bottom of the LCD.
- The display will show the weight and the units of weight currently in use. The stable indicator  will be on. To change the weighing units, press **[Mode]** to cycle through the options of units those are enabled. See the Parameter section to enable or disable the weighing units.
- The accumulated value in the memory will be cleared when a new weighing unit or during recalling the memory, % weighing or parts counting is selected.

4.4 PERCENT WEIGHING

- The scale will allow a sample weight to be shown as 100%. Then any other weight placed on the scale will be displayed as a percentage of the original sample.
- For example is 350g is placed on the scale and the **[%]** key is pressed the display will show 100.00%. Removing the 350g weight and place a 300g weight on the scale. The display will show 85.71% as 300g is 85.71% of 350g.
- **Note:** The scale may jump by large numbers unexpectedly if small weights are used to set the 100% level. For example, if only 23.5g is on a scale with 0.5g increments and the scale is set to 100%, the display will show 100.00%. However, a small change of weight will cause the display to jump to 102.13%, as one scale division (0.5g) increase to 24.0g will be equivalent to a 2.13% increase.
- Pressing the **[%]** key again will return the scale to normal weighing.

4.5 PARTS COUNTING

- When the scale is in normal weighing mode, pressing the **[Smpl]** key will start the parts counting function.
- Before beginning, tare the weight of any container that will be used, leaving the empty container on the scale.
- Place the number of samples on the scale. The number should match the options for parts counting, 10, 20, 50, 100 or 200 pieces.
- Press the **[Smpl]** key.
- The scale will initially show "**SP 10**" asking for a sample size of 10 parts. Press **[Mode]** to cycle through the options: 10, 20, 50, 100, 200 and back to 10.
- Press **[Smpl]** again when the number matches the number of parts used for the sample. As more weight is added the display will show the number of parts (**PCS**) with respect to the chosen sample size.
- Press **[Mode]** to display unit weight (**W/P**), total weight (g) or the count (**PCS**). The total and the unit weight are shown in the current units.
- Press **[Smpl]** to return to normal weighing.

4.6 ACCUMULATION

- When the scale is set for automatic accumulation, the weight will be added to the memory when the scale becomes stable. **The scale must return to zero before another weight is added.**
- When the scale is set to manual accumulation (See the Parameter Section) the weight displayed will be stored in memory when the **[Print]** key is pressed and the weight is stable.
- The display will show "**ACC 1**" followed by the total value in the memory for 2 seconds before returning to displaying the weight of the item on the scale.

- The weight will be output to a printer or PC.
- Remove the weight, allowing the scale to return to zero and put a second weight on.
- Press **[Print]**, the display will show "**ACC 2**" followed by the new total in the memory for 2 seconds before returning to displaying the weight of the item on the scale.
- Continue until all weights have been added.
- To view the totals in memory press the **[Print]** key when the scale is at zero. The display will show "**ACC xx**" (where "**xx**" is the total number of readings) and the total weight, before returning to zero.
- The total will also be printed via the RS-232 interface.
- To clear the memory, press **[Smpl]** immediately after pressing **[Print]**.

5.0 PARAMETERS

- The scale has 5 parameters that can be chosen by the user to set the scale.
- To set the parameters press the **[Mode]** key during self-checking test.
- After a few seconds, the display will show the first function "**F1 UNT**".
- To view the current settings of each parameter, press the **[Zero]** key.
- Press the **[Zero]** key again to cycle through the other parameters along with their current settings. For example, if "**off**" is displayed with the weighing unit Pounds, the user will not be able to use this unit while weighing a sample.
- Press **[Mode]** to change the settings of a particular parameter. For example, to enable the weighing unit pounds change the setting to "**on**" by pressing **[Mode]** now.
- Use the **[Print]** key to leave a parameter unchanged.

The following parameters are available:

FUNCTION	DESCRIPTION
F1 UNT	Sets the units to be used (See section 5.1) g / ct / Lb / OZ / d / GN / OZt / dWt / MM / TL.T / TL.C / TL.t / t / N / g2.
F2 EL	Sets the backlight (See section 5.2) EL on: backlight always on EL AU: backlight automatically turns on when a key is pressed EL off: backlight always off
F3 Ser	Sets the print parameters (See section 5.3)
F4 off	Sets the auto switch-off parameter (See section 5.4)
TECH	Pressing [Zero] will allow the user to enter the technical parameters setting mode. It is recommended not to proceed with the settings of these parameters as those are set up at the factory.

5.1 SELECTING THE UNITS

- When “**F1 Unt**” is displayed, press the **[Zero]** key to view the current settings of each unit.
- Press **[Zero]** again to cycle through the other units along with their current settings. For example, if “**off**” is displayed with the weighing unit Carats, the user will not be able to use this unit while weighing.
- Press **[Mode]** to change the settings of a particular unit. For example, to enable the weighing unit Carats, change the setting to “**on**” by pressing **[Mode]** now.
- Use the **[Print]** key to leave a parameter unchanged.
- While weighing a sample, the display will show the weight and the units of weight currently in use. To view the weight in other units (which are enabled), press **[Mode]**.
- The following table shows different units which are available to the user and the conversion factors for each.

Sl. No.	Name of the Units	Description	Conversion Factor	Display Symbol
01	Grams	A standard metric unit	1.0	g
02	Carats	Used for weighing jewellery and gems, etc.	5.0	ct
03	Pounds	Standard weighing unit in UK/USA.	0.002205	Lb
04	Ounce	Avoirdupois ounce. 16 ounces make a pound.	0.03528	OZ
05	Drams	An ancient unit of weight. Equals to 1/16 th of an ounce.	0.5645	d
06	Grains	A basic weighing unit in the imperial system. Used to weigh gun powder.	15.432	GN
07	Ounce Troy	Troy ounce- used for weighing gold, silver and in pharmacy.	0.03216	OZt
08	Penny-weight	Pennyweight was the weight of a silver penny in medieval England. Equals to 1/20 th of an Ounce Troy.	0.6432	dWt
09	Mommes	A weighing unit used in Japan to weigh pearls.	0.26667	MM
10	Taels Hk.	Hongkong Taels- used to weigh coral, pearls, etc.	0.02675	TL.T
11	Taels S.	Singapore Taels	0.02646	TL.C
12	Taels T.	Taiwan Taels	0.02675	TL.t
13	Tical	An Asian weighing unit	0.08576	t
14	Newtons	Used to measure force	0.009808	N
15	Grams	Grams with last digit suppressed	1.0	g2

5.2 SETTING OF THE BACKLIGHT

- The backlight may be enabled or disabled by the user.
- If the backlight is disabled, the battery life will be maximised.
- The following settings are available:

EL AU	Sets the backlight to operate automatically when a weight is placed on the scale or a key is pressed.
EL Off	Sets the backlight to be off.
EL On	Sets the backlight to be on for full time.

- When “**F2 EL**” is displayed, press the [**Zero**] key to view the current setting for the backlight.
- Press [**Mode**] to scroll through other settings.
- Press [**Zero**] to store a particular setting.
- Use the [**Print**] key to leave a parameter unchanged.

5.3 SETTING THE PRINTING PARAMETERS

When “**F3 Ser**” is displayed, press [**Zero**] to view the first printing parameter.

5.3.1 Selecting the communication port

- The selected port, for example “**5 232**” will be displayed.
- Press [**Mode**] to cycle through the other options. The user can select “**5 232**” or “**5 USB**” as the communication port. Currently, only RS-232 interface is available and the scale is set with this port only.
- Press [**Zero**], to view the next printing parameter.

5.3.2 Setting the print mode

- The current setting of the print mode is displayed,
- Press [**Mode**] to cycle through the other options.
- The following options are available:

P1 Prt	The scale sends the accumulated weights to the communication port, whenever the [Print] key is pressed.
P2 Con	It will set the RS-232 interface to print the weights continuously and the accumulation function is disabled.
P3 AUT	The weighing results will be sent to the communication port automatically whenever a weight is placed on the platform.

- Press [**Zero**], to view the next printing parameter.

5.3.3 Setting the baud rate

- The current baud rate setting will be displayed.
- Press [**Mode**] to cycle through the other options.
- The following settings are available:

b 600
b 1200
b 2400
b 4800 (default value)
b 9600

- Press [**Zero**] to view the next printing parameter.

5.3.4 Parity settings

- The current Parity setting will be displayed.
- Press **[Mode]** to cycle through the other options.
- The following settings are available:

8 n 1	8 data bits, no parity
7 E 1	7 data bits, even parity
7 O 1	7 data bits, odd parity

- Press **[Zero]**, the display will go back showing **“F3 Ser”**.
- Press **[Mode]** to go to the next parameter which is **“F4 off”**.

5.4 SETTING OF AUTO-SWITCH-OFF

- The Auto switch-off time may be set up by the user.
- When **“F4 off”** is displayed, press the **[Zero]** key to view the current setting for the backlight.
- Press **[Mode]** to scroll through other settings (0, 5, 10, 20 and 30 minutes).
- Press **[Zero]** to store a particular setting.
- Use the **[Print]** key to leave a parameter unchanged.

5.5 TECHNICAL PARAMETERS

- Next parameter is **“TECH”**. This allows the user to enter the Technical Parameters section.

Note: It is recommended not to proceed with the settings of the Technical Parameters which are set up at the factory and are often referred to as Service Parameters. Check the Service Manuals for more details.

- Press **[Print]** to return to weighing. The scale will run the self-test before displaying the zero along with the last selected unit.

6.0 CALIBRATION

- This parameter allows the user to calibrate the scale any time during the operation.
- Switch the scale off and then on it again by pressing **[On/Off]**. During the self-test press **[Smpl]** and **[Print]** together.
- Display will show "**unLoAd**". Remove all weights from the pan.
- Wait for the stability indicator to be on and then press **[Zero]**.
- The display will then show the first calibration weight request.
- Press **[Mode]** to scroll through the other calibration weights.
- Press **[Zero]** to select calibration weight. The display will show "**LoAd**".
- Place this weight on the platform and press **[Zero]** when the stability indicator will be on to show the value is stable.
- If the calibration is complete, the scale will show "**PASS**" and will return to normal weighing counting back to zero. Remove the calibration weight at this stage.
- If the wrong calibration weight is used, the scale will show "**FAIL H**" (when the weight is higher) or "**FAIL L**" (when the weight is lower). Repeat the process using the correct calibration weight.

Calibration weights:

Model #	ACB _{plus} 150	ACB _{plus} 300	ACB _{plus} 600	ACB _{plus} 600H	ACB _{plus} 1000	ACB _{plus} 1500	ACB _{plus} 3000
Weight 1	50g	100g	200g	200g	500g	500g	1000g
Weight 2	100g	200g	400g	400g	1000g	1000g	2000g
Weight 3	150g	300g	600g	600g	-	1500g	3000g

7.0 COMMUNICATION WITH A COMPUTER/PRINTER

The ACB_{plus} series of scales come with a standard RS-232 interface.

The standard Interface parameters are: Connection details are:

RS-232 output of weighing data
ASCII code
4800 Baud
8 data bits
No Parity

Connector: 9 pin d-subminiature socket
Pin 3 Output
Pin 2 Input
Pin 5 Signal Ground

Data Format for normal weighing operations, parts counting or recalling of totals from memory will all be different.

Normal Output: G S _ X X X . X X u u u

GS	123.45g	GS for Gross Weight, NT for Net Weight and u for unit of weight
No.	1	This number increments every time a new value is stored in memory
Total	123.45g	The total value stored in memory
<lf>		Includes 2 line feeds
<lf>		

Input commands format:

The scale can be controlled with the following commands. The commands must be sent in upper case letters, i.e. "T" not "t".

T<cr><lf>	Tares the scale to display the net weight. This is the same as pressing [Tare] key.
Z<cr><lf>	Sets the zero point for all subsequent weighing. Display shows zero.
T5.345<cr><lf>	Would be same as entering a preset tare value of 5.345 from keypad
P<cr><lf>	Prints the results to a PC or printer using the optional RS-232 interface. It also adds the value to the accumulation memory if the accumulation function is not set to automatic.

8.0 ERROR MESSAGES

During the initial power-on testing or during operation it is possible that the scale may show an error message. The meaning of the error messages is described below.

ERROR CODE	DESCRIPTION	POSSIBLE CAUSES
Err 4	Initial Zero is greater than allowed (4% of maximum capacity) when power is turned on or when the [Zero] key is pressed,	<ul style="list-style-type: none"> • Weight on the pan when turning on. • Excessive weight on the pan when zeroing the scale. • Improper calibration of the scale. • Damaged load cell. • Damaged Electronics.
Err 5	Keyboard Error.	<ul style="list-style-type: none"> • Improper operation of the scale.
Err 6	A/D count is not correct when turning the scale on	<ul style="list-style-type: none"> • Load cell damaged. • Electronics damaged.
Err 9	A/D count is not stable when turning the scale on	<ul style="list-style-type: none"> • Initial instability during turning on which will get adjusted automatically • There may be movement, vibration or dirt on scale during turning on.

If an error message is shown, repeat the procedure that caused the message such as turning the scale on, calibration or any other functions. If the error message is still shown, contact your dealer for further support.



Manufacturer's Declaration of Conformity

This product has been manufactured in accordance with the harmonised European standards, following the provisions of the below stated directives:

Electro Magnetic Compatibility Directive 89/336/EEC

Low Voltage Directive 73/23/EEC

Adam Equipment Co. Ltd.
Bond Avenue
Denbigh East Estate
Milton Keynes, MK1 1SW
United Kingdom

FCC COMPLIANCE

This equipment has been tested and found to comply with the limits for a Class A digital device, pursuant to Part 15 of the FCC Rules. These limits are designed to provide reasonable protection against harmful interference when the equipment is operated in a commercial environment. The equipment generates, uses, and can radiate radio frequency energy and, if not installed and used in accordance with the instruction manual, may cause harmful interference to radio communications. Operation of this equipment in a residential area is likely to cause harmful interference in which case the user will be required to correct the interference at his own expense.

Shielded interconnect cables must be employed with this equipment to insure compliance with the pertinent RF emission limits governing this device.

Changes or modifications not expressly approved by Adam Equipment could void the user's authority to operate the equipment.

ADAM EQUIPMENT is an ISO 9001:2000 certified global organisation with more than 30 years experience in the production and sale of electronic weighing equipments. Products are sold through a world wide distributor network -supported from our company locations in the UK, USA and SOUTH AFRICA. The company and their distributors offer a full range of Technical Services such as on site and workshop repair, preventative maintenance and calibration facilities.

ADAM's products are predominantly designed for the Laboratory, Educational, Medical and Industrial Segments. The product range can be classified as follows:

- Analytical and Precision Laboratory Balances
- Top Loading Scales for Educational establishments
- Counting Scales for Industrial and Warehouse applications
- Digital Weighing/Check-weighing Scales
- High performance Platform Scales with extensive software features including parts counting, percent weighing etc.
- Digital Electronic Scales for Medical use
- Retail Scales for price computing

<p>Adam Equipment Co. Ltd. Bond Avenue Milton Keynes MK1 1SW UK</p> <p>Phone: +44 (0)1908 274545 Fax: +44 (0)1908 641339</p> <p>e-mail: sales@adamequipment.co.uk</p>	<p>Adam Equipment Inc. 26, Commerce Drive Danbury, CT 06810 USA</p> <p>Phone: +1 203 790 4774 Fax: +1 203 792 3406</p> <p>e-mail: sales@adamequipment.com</p>	<p>Adam Equipment S.A. (Pty) Ltd. P.O. Box 1422 Kempton Park 1620 Johannesburg Republic of South Africa</p> <p>Phone +27 (0)11 974 9745 Fax: +27 (0)11 392 2587</p> <p>e-mail: sales@adamequipment.co.za</p>
---	---	--

© Copyright by Adam Equipment Co. Ltd. All rights reserved. No part of this publication may be reprinted or translated in any form or by any means without the prior permission of Adam Equipment.

Adam Equipment reserves the right to make changes to the technology, features, specifications and design of the equipment without notice.

All information contained within this publication was to the best of our knowledge timely, complete and accurate when issued. However, we are not responsible for misimpressions which may result form the reading of this material.

The latest version of this publication can be found on our Website.

Visit us at [**www.adamequipment.com**](http://www.adamequipment.com)