



KERN EOB

Version 1.3 11/2004

Operation Instructions Electronic Platform Balances

Table of contents:

1	Technical data	18
2	Declaration of conformity	19
3	Fundamental information (general)	20
3.1	Intended use	20
3.2	Inappropriate use	20
3.3	Guarantee	20
3.4	Monitoring the test substances	21
4	Fundamental safety information	21
4.1	Observe the information in the operating instructions	21
4.2	Staff training	21
5	Transport and storage	21
5.1	Acceptance check	21
5.2	Packaging	21
6	Unpacking, installation and commissioning	22
6.1	Place of installation, place of use	22
6.2	Installation	23
6.2.1	Unpacking the Balance	23
6.2.2	Package volume	23
6.2.3	Mounting instructions for using wall bracket	23
6.3	Mains supply	24
6.4	Battery Operation	24
6.5	Initial start-up	24
6.6	Adjustment	25
6.7	Adjusting	25
7	Operation	26
7.1	Weighing	26
7.2	Taring (TARE key)	26
7.3	Plus / Minus Weighings	27
7.4	Weight units	27

8	<i>Maintenance, upkeep, disposal</i>	28
8.1	Cleaning	28
8.2	Maintenance, upkeep	28
8.3	Disposal	28
9	<i>Troubleshooting</i>	29

1 Technical data

KERN	EOB 6K5	EOB 15K10	EOB 35K20	EOB 60K50	EOB 150K100	EOB 300K100
<i>Readout</i>	5 g	10 g	20 g	50 g	100 g	100 g
<i>Weighing range</i>	6 kg	15 kg	35 kg	60 kg	150 kg	300 kg
<i>Taring range (subtractive)</i>	6 kg	15 kg	35 kg	60 kg	150 kg	300 kg
<i>Adjusting weight, not added (Class)</i>	5 kg (M3)	10 kg (M3)	20 kg (M3)	40 kg (M3)	100 kg (M3)	200 kg (M3)
<i>Stabilisation time (typical)</i>	2 - 3 sec.					
<i>Optimal temp. of operation</i>	+ 10° C + 30° C					
<i>Humidity</i>	max. 80 % (non-condensing)					
<i>Size (W x D x H) mm</i>	310 x 300 x 55 (platform) 220 x 90 x 44 (terminal)					
<i>Weighing plate mm</i>	310 x 300					
<i>Weight kg (net)</i>	4					

KERN	EOB 60K50L	EOB 150K100L	EOB 300K200L
<i>Readout</i>	50 g	100 g	200 g
<i>Weighing range</i>	60 kg	150 kg	300 kg
<i>Taring range (subtractive)</i>	60 kg	150 kg	300 kg
<i>Adjusting weight, not added (Class)</i>	40 kg (M3)	100 kg (M3)	200 kg (M3)
<i>Stabilisation time (typical)</i>	2 - 3 sec.		
<i>Optimal temp. of operation</i>	+ 10° C + 30° C		
<i>Humidity</i>	max. 80 % (non-condensing)		
<i>Size (W x D x H) mm</i>	550 x 550 x 55 (platform) 220 x 90 x 44 (terminal)		
<i>Weighing plate mm</i>	550 x 550		
<i>Weight kg (net)</i>	15		

2 Declaration of conformity



The electronic precision balances

Typ:	KERN EOB6K5 KERN EOB15K10 KERN EOB35K20 KERN EOB60K50 KERN EOB 60K50L	KERN EOB150K100 KERN EOB 150K100L KERN EOB 300K100 KERN EOB 300K200L
------	---	---

Correspond to the following EC requirements:

EC-EMC-directive	version 89/336/ECC
------------------	--------------------

Compatible norms are, in particular

EN 61000-3-2 : ED 2 2001 EN 61000-3-3 : 1995 EN 50081-1 (EN 55022) :1998 Class B EN 50082-1 (EN 61000-4-2) :1995 EN 50082-1 (EN 61000-4-3) :1995	EN 50082-1 (ENV 50204) :1992 EN 50082-1 (EN 61000-4-4) :1995 EN 50082-1 (EN 61000-4-5) :1995 EN 50082-1 (EN 61000-4-6) :1996 EN 50082-1 (EN 61000-4-11) :1994
--	---

If a change is made to the above mentioned appliances without consulting KERN this declaration will become invalid

Date: 15. 11. 2004

Signed:

Gottl. KERN & Sohn GmbH
Management

Gottl. KERN & Sohn GmbH, Ziegelei 1, D-72322 Balingen-Frommern, Tel. +49-07433/9933-0, Fax +49-07433/9933-149

3 Fundamental information (general)

3.1 Intended use

The balance you have acquired serves to determine the weighing value of the material to be weighed. It is intended to be used as a “non-automatic” balance, i.e. the material to be weighed is manually and carefully placed in the centre of the weighing plate. The weighing value can be read off after a stable weighing value has been obtained.

3.2 Inappropriate use

Do not use the balance for dynamic weighing. In the event that small quantities are removed or added to the material to be weighed, incorrect weighing results can be displayed due to the “stability compensation” in the balance. (Example: Slowly draining fluids from a container on the balance.)

Do not leave a permanent load on the weighing plate. This can damage the measuring equipment.

Be sure to avoid impact shock and overloading the balance in excess of the prescribed maximum load rating (max.), minus any possible tare weight that is already present. This could cause damage to the balance.

Never operate the balance in hazardous locations. The series design is not explosion-proof.

Structural alterations may not be made to the balance. This can lead to incorrect weighing results, faults concerning safety regulations as well as to destruction of the balance.

The balance may only be used in compliance with the described guidelines. Varying areas of application/planned use must be approved by KERN in writing.

3.3 Guarantee

The guarantee is not valid following

- non-observation of our guidelines in the operating instructions
- use outside the described applications
- alteration to or opening of the device
- mechanical damage and damage caused by media, liquids
- natural wear and tear
- inappropriate erection or electric installation
- overloading of the measuring equipment

3.4 Monitoring the test substances

The metrology features of the balance and any possible available adjusting weight must be checked at regular intervals within the scope of quality assurance. For this purpose, the answerable user must define a suitable interval as well as the nature and scope of this check. Information is available on KERN's home page (www.kern-sohn.com) with regard to the monitoring of balance test substances and the test weights required for this. Test weights and balances can be adjusted quickly and at a reasonable price in KERN's accredited DKD calibration laboratory (return to national normal).

4 Fundamental safety information

4.1 Observe the information in the operating instructions

Please read the operating instructions carefully before erecting and commissioning, even if you already have experience with KERN balances.

4.2 Staff training

The device may only be operated and looked after by trained members of staff.

5 Transport and storage

5.1 Acceptance check

Please check the packaging immediately upon delivery and the device during unpacking for any visible signs of external damage.

5.2 Packaging

Please retain all parts of the original packaging in case it should be necessary to return items at any time.

Only the original packaging should be used for return consignments.

Before despatch, disconnect all attached cables and loose/movable parts.

6 Unpacking, installation and commissioning

6.1 Place of installation, place of use

The balance is constructed in such a way that reliable weighing results can be achieved under normal application conditions.

By selecting the correct location for your balance, you will be able to work quickly and precisely.

Therefore please observe the following at the place of installation:

- Place the balance on a firm, level surface;
- Avoid extreme heat as well as temperature fluctuation caused by installing next to a radiator or in the direct sunlight;
- Protect the balance against direct draughts due to open windows and doors;
- Avoid jarring during weighing;
- Protect the balance against high humidity, vapours and dust;
- Do not expose the device to extreme dampness for longer periods of time. Inadmissible bedewing (condensation of air moisture on the device) can occur if a cold device is taken into a significantly warmer environment. In this case, please acclimatise the device for approx. 2 hours at room temperature after it has been disconnected from the mains.
- Avoid static charging of the material to be weighed, weighing container and windshield.

Major display deviations (incorrect weighing results) are possible if electromagnetic fields occur as well as due to static charging and instable power supply. It is then necessary to change the location.

6.2 Installation

Install the balance in such a fashion that the weighing plate is absolutely horizontal.

6.2.1 Unpacking the Balance

Carefully remove the balance from the packaging and out of the plastic covering, then place the balance on the assigned position.

6.2.2 Package volume

Serial fittings:

KERN EOB

- Platform and display device
- Mains device
- Wall bracket (with anchoring screws)
- Operating instructions

6.2.3 Mounting instructions for using wall bracket

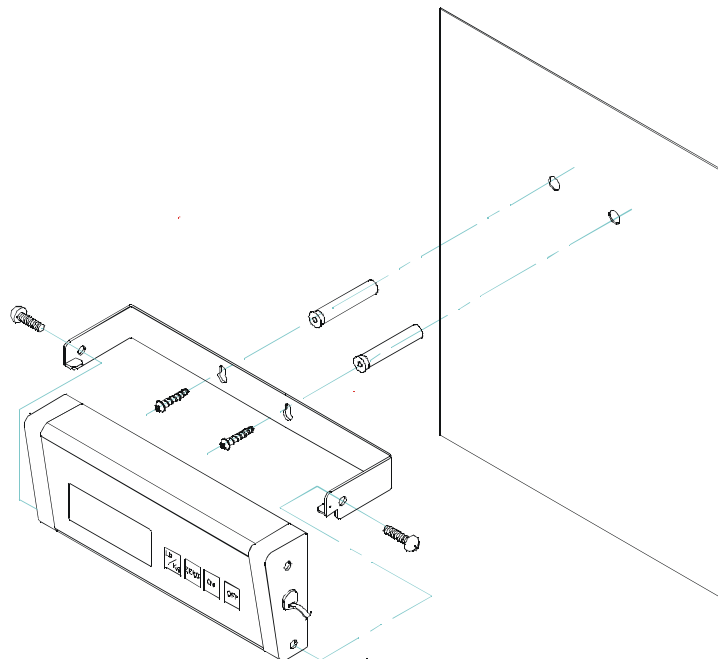

6.3 Mains supply

Electric power supply is by means of the external mains supply circuit. The printed voltage level must comply with the local voltage.

Only use original KERN mains supply circuits. The use of other makes is subject to approval by Kern.

6.4 Battery Operation

Remove the battery cover underneath the weighing scale. Connect 6 x 1,5V round cells. Re-insert the battery cover.

Battery conservation through automatic power-off 3 minutes after ending a weighing operation.

When the battery power is used up the display will show "LO". Press the **OFF** key and change the batteries at once.

When the balance is not in use for a longer period of time remove batteries and keep them separately. Leakage of battery liquid might damage the balance.

6.5 Initial start-up

A warm-up time of 5 minutes stabilises the measured values after switching on.

The accuracy of the balance depends on the local acceleration of the fall.

Please be sure to observe the information in the chapter on adjusting.

6.6 Adjustment

As the acceleration value due to gravity is not the same at every location on earth, each balance must be coordinated – in compliance with the underlying physical weighing principle - to the existing acceleration due to gravity at its place of location (only if the balance has not already been adjusted to the location in the factory). This adjustment process must be carried out during the initial start-up, after change in location and variation of surrounding temperature. It is also recommendable to adjust the balance periodically during weighing operation in order to obtain exact measured values

6.7 Adjusting

Balance accuracy can be checked and adjusted at any time using an adjusting weight.

Method of adjusting:

Observe stable ambience conditions. A short warming-up time of approx. 5 minutes for stabilisation purposes is useful.

Press **UNIT** key and hold depressed until the exact size of the adjusting weight flashes on the display panel, "Load" appears on the display panel alternately. Place the adjusting weight in the centre of the weighing plate. The value of the size of the adjusting weight will stabilise a short time later.

Keep the adjusting weight next to the balance. A daily balance accuracy check is recommended for applications relevant to quality.

7 Operation

7.1 Weighing

Switch the balance on by pressing the **ON/** key.

The balance will show "88888" for approx. 3 seconds and then change to "0". Now it is ready for use.

Important: If the display does not show "0" press the TARE key.

Only now (!) place object on the weighing pan. Make sure that the weighing object does not strike or touch the housing or base.

Now the weight will be indicated. After a successful „resting position“ control a small triangle will appear on the far right at the bottom of the display.

If the object should be heavier than the weighing range allowance, the symbol Err(overload) will appear on the display and a tone can be heard.

7.2 Taring (TARE key)

Switch the balance on by pressing the **ON** key, then wait for the "0" indication.

Place the jiffy on the weighing pan and press the **TARE** key. Display again shows "0". Now the weight of the jiffy is memorised internally.

By pressing the **TARE** key after a weighing procedure, "0" will appear on the display again.

The taring procedure can be repeated continuously, for instance when mixing several components.

The limit is reached when the full weighing range is overlaid.

After having removed the jiffy the total weight will appear as a minus indication.

7.3 Plus / Minus Weighings

For instance to control piece-weights, filling process control etc.

Switch the balance on by pressing the **ON** key, then wait until "0" is indicated.

Place rated weight on the weighing pan and tare on "0" by pressing the **TARE** key.
Remove rated weight.

Place the objects on the weighing pan successively, the balance will show any deviation from the rated weight in "+" and "-".

According to the same procedure packages with the same weight, related to a rated weight, can be produced.

Return to the weighing mode by pressing the **TARE** key.

7.4 Weight units

Two units are available: "kg" and "lb".

The weight unit is chosen by pressing the "**Unit**" key.

A lamp to the right of the display signalises the respective unit.

Unit conversion: **1 kg = 2.20462 lb**

8 Maintenance, upkeep, disposal

8.1 Cleaning

Please disconnect the device from the operating voltage before cleaning.

Only use a cloth dampened with mild suds and not aggressive cleaning agents (solvents or similar). Please ensure that fluids are not able to get into the device and rub off using a clean, soft cloth.

Loose sample residue/powder can be removed carefully using a brush or hand vacuum cleaner.

Remove any spilt material to be weighed immediately.

8.2 Maintenance, upkeep

The device may only be opened by trained service engineers authorised by KERN. Disconnect from the mains supply before opening.

8.3 Disposal

The operating company shall dispose of the packaging and the device in compliance with the valid national or regional law of the operating location.

9 Troubleshooting

The balance should be switched off for a short time following an interruption in the programme sequence and disconnected from the mains supply. It is then necessary to repeat the weighing process from the beginning.

Help:

Interruption

Possible cause

Weight display is not illuminated.

- *The balance is not switched on.*
- *The mains supply connection has been interrupted (mains cable not plugged in/faulty).*
- *Power supply interrupted. .*

The weight display changes continually

- *Draught/air movement*
- *Table/floor vibrations*
- *The weighing plate is in contact with foreign matter.*
- *Electromagnetic fields / static charging (choose different location/switch off interfering device if possible)*

The weighing result is obviously incorrect

- *The balance display is not set to zero*
- *Adjustment is no longer correct.*
- *Great fluctuations in temperature.*
- *Electromagnetic fields / static charging (choose different location/switch off interfering device if possible)*

Switch the balance off if other error messages should appear and then switch on again. Contact the manufacturer if the error message does not disappear.